

CONVENTIONAL - Rate of Rise Thermal Detector Model ECO1005

Overview

Features

- Low profile design
- Low current draw
- 58°C operating temperature
- Operates at 12 and 24VDC
- Remote alarm test feature
- Easy Maintenance
- Range of detector bases available
- Remote LED Option
- Approved to EN54 –5:2000 Class A1R
- Extended warranty



199n/01



G201016



0832-CPD-0066

Description

The ECO1005 thermal detector belongs to System Sensor's ECO1000 range of detectors. ECO1000 is a range of conventional detectors, which have been produced using the latest in manufacturing technology and supplied with an array of advanced features, making them 'better by design'.

The ECO1005 thermal detector uses a state of the art thermal element combined with an application specific integrated circuit (ASIC) to provide quick and accurate detection of fires. The detector incorporates both rate of rise and static elements and is suitable for all areas where the ambient conditions do not normally exhibit rapid changes in temperature.

A laser-based hand held Remote Test Unit can be used in conjunction with the range of ECO1000 detectors for alarm test purposes. The unit transmits a coded message, preventing spurious alarms being generated by other laser-based devices. With a range of several metres, the hand held test unit provides an effortless way of remotely alarm testing the range of ECO1000 detectors and removes the need for any direct physical access to the detector by the user.

The ECO1005 detector also has an integral LED, which illuminates to provide a local alarm signal. This latches on, and remains illuminated until the detector is reset by a momentary power interruption. An optional remote LED annunciator may be used to repeat any alarm signal.

A variety of detector bases can be used with the ECO1005 detector, providing application flexibility and compatibility with a wide range of Fire Alarm Control Panels. All bases are fitted with a shorting spring to permit circuit testing prior to fitting the detector and have a tamper resistant feature, which when activated prevents removal of the detector without the use of a tool.

All System Sensor products are covered by our extended 3-year warranty.

Architect/Engineer Specifications

ECO1005 Rate of Rise Thermal Detector

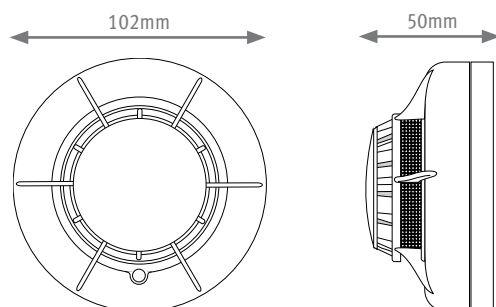

Electrical Specifications

Operating Voltage Range	8 to 30VDC (Nominal 12/24VDC)
Maximum Standby Current @25°C	70µA @ 24VDC
Maximum Permissible Alarm Current	80mA (current limited by control panel)

Environmental Specifications

Application Temperature Range (see note 1)	-30°C to 70°C
Humidity	5% to 95% Relative Humidity (non-condensing)

Mechanical Information

Height	40.5mm (plus 9.5mm for standard base)
Diameter	102mm
Weight	70g (plus 45g for standard base)
Wire Gauge for Terminals	0.4mm ² to 2.0mm ²
Colour	Approximates to RAL9016
Material	ABS

Product Range

Bases (see note 2)	
ECO1000B Standard Base	ECO1000BSD Standard base with Schottky diode
ECO1000R Resistor base 470 Ohm	ECO1000BRSD Resistor base 470 Ohm with Schottky diode
ECO1000DB Deep base	ECO1000DBSD Deep base with Schottky diode
ECO1000DBR Deep resistor base 470 Ohm	ECO1000DBRSD Deep resistor base 470 Ohm with Schottky diode
ECO1000BREL12L Relay base 12V Latching	ECO1000BREL12NL Relay base 12V Non –latching
ECO1000BREL24NL Relay base 24V Latching	
Accessories	
ECO1000RTU Remote Test Unit	
Other Detectors	
ECO1002 Photoelectric/Thermal Detector	ECO1003 Photoelectric Detector
ECO1004T 78°C Fixed Temperature Thermal Detector	ECO1005T 58°C Fixed Temperature Thermal Detector

Notes

Bases with other resistor values are available to suit the requirements of most Fire Alarm Control Panels.

System Sensor Europe (Technical Services)

Charles Avenue
Burgess Hill
RH15 9TQ
United Kingdom

Tel: +44 (0)1444 238820
Fax: +44 (0)1444 248123
Email: sse.technical@systemsensoreurope.com
www.systemsensoreurope.com

Copyright © 2005 System Sensor. All rights reserved.
All technical data is correct at time of publication and is subject to change without notice. All trademarks acknowledged.
Installation information: in order to ensure full functionality, refer to the installation instructions as supplied.