



Fire Alarm Control Panel

CSP-204

CSP-208

CSP-104

CSP-108

Installation and Programming Manual



Firmware version 1.00



csp-x_i_en 05/13

SATEL sp. z o.o.
ul. Schuberta 79
80-172 Gdańsk
POLAND
tel. 58 320 94 00
info@satel.pl
www.satel.eu

The CSP-104 / CSP-108 / CSP-204 / CSP-208 Fire Alarm Control Panel complies with essential requirements of the European Union Directives:

CPD 89/106/EEC Construction Products Directive;

EMC 2004/108/EC Electromagnetic Compatibility Directive;

LVD 2006/95/EC Low Voltage Directive.

An EC Certificate of Conformity No. 1438/CPD/0317 was issued by the CNBOP-PIB Jozefow Certification Body for the CSP-104 / CSP-108 / CSP-204 / CSP-208 fire alarm control panel to confirm its compliance with EN 54-2:1997+A1:2006 requirements.

The Certificate of Conformity can be downloaded from the www.satel.eu website.



1438

SATEL Sp. z o.o. • ul. Franciszka Schuberta 79 • 80-172 Gdańsk • POLAND

13

1438/CPD/0317

EN 54-2:1997+A1:2006

CSP-104 / CSP-108 / CSP-204 / CSP-208 Fire Alarm Control Panel

conventional, to be used in buildings.

Provided options:

- output for fire alarm devices
- output to fire alarm routing equipment
- signal delay at the outputs
- coincidence detection (dependencies)
- alarm counter
- complete power failure
- output to fault warning routing equipment
- test condition
- standard Input / Output interface

Additional functions, inputs and outputs: see specifications contained in this manual.

CONTENTS

1. Introduction.....	3
2. Function of the fire alarm control panels	3
3. Features.....	3
4. Description of the control panels.....	4
4.1 Terminals.....	6
4.2 Front panel	6
4.2.1 LED indicators	8
4.2.2 Buttons	10
4.2.3 Key switch	11
4.2.4 Display.....	11
5. Installation of the control panel.....	11
5.1 Mounting the control panel	11
5.2 Connections	13
5.2.1 Zones	13
5.2.2 Programmable inputs	14
5.2.3 Sounders	15
5.2.4 Outputs to the routing equipment	15
5.2.5 Relay outputs	15
5.2.6 Power outputs	15
5.2.7 Communication bus.....	16
5.2.8 Main power supply	16
5.2.9 Backup power supply	18
6. Access levels	18
6.1 Level 1 – all users.....	18
6.2 Level 2 – authorized users	18
6.3 Level 3 – control panel programming	19
7. Programming	19
7.1 Description of functions, parameters and options.....	19
7.1.1 Zone parameters	19
7.1.2 Sounder parameters.....	20
7.1.3 Routing outputs	20
7.1.4 Input parameters	20
7.1.5 Output parameters	20
7.1.6 Earth fault monitoring	21
7.1.7 Global settings.....	21
7.1.8 Panels	22
7.1.9 Code.....	22
7.2 DCSP program	22
7.2.1 Connecting the control panel to computer.....	22
7.2.2 Starting the programming.....	23
7.2.3 Program description	24
7.3 Programming with buttons	25
7.3.1 Beeps during programming	25
7.3.2 Programming the CSP-204 and CSP-208 control panels	25
7.3.3 Programming the CSP-104 and CSP-108 control panels	28
8. Repeater panels	36
8.1 Features	36

8.2	Description of repeater panels	36
8.2.1	Front panel	37
8.3	Installation of the repeater panel.....	40
8.3.1	Mounting the repeater panel	40
8.3.2	Connections	40
9.	CSP-ETH module for communication with the virtual panel.....	40
9.1	Electronics board description.....	40
9.2	Installation	41
9.3	Using the virtual panel	42
10.	Checking the fire alarm control panel for proper functioning	42
11.	Maintenance	44
11.1	Fuse replacement in the battery charging system	44
12.	Specifications	46
12.1	Control panels.....	46
12.2	Repeater panels	47
12.3	CSP-ETH module	48

1. Introduction

This manual covers the following microprocessor based fire alarm control panels:

CSP-104 - 4 zone conventional fire alarm control panel,

CSP-108 - 8 zone conventional fire alarm control panel,

CSP-204 - 4 zone conventional fire alarm control panel with LCD display,

CSP-208 - 8 zone conventional fire alarm control panel with LCD display.

The manual also describes the optional components of the fire alarm control panel, i.e. repeater panels and CSP-ETH module for communication with virtual panel.

Prior to installation, read this manual carefully in order to avoid mistakes and errors which might result in malfunctioning of or even damage to the equipment. The manual contains guidelines for installation of the fire alarm control panel, its programming and connecting other devices to it. This manual describes no principles of designing the fire detection and fire alarm systems.

2. Function of the fire alarm control panels

The CSP-104, CSP-108, CSP-204 and CSP-208 control panels are designed for:

- supervision of the operation of detectors and manual call points;
- supervision of the operation of other external devices;
- control of sounders;
- control of fire alarm and fault warning routing equipment;
- control of other external devices.

The above functions make it possible to detect a fire at its earliest stages of development and inform the building users about the fact with the use of acoustic and/or optical signaling, as well as to notify the appropriate services. This enables an early fire fighting action to be taken. The system can also automatically start the appropriate fire protection equipment.

3. Features

- 4 (CSP-104 and CSP-204) or 8 (CSP-108 and CSP-208) zones.
- Support for up to 32 detectors or 10 manual call points (MCP) by each zone.
- Coincidence detection (type A and type B dependencies).
- 4 programmable inputs (including confirmation of fire alarm and fault warning transmissions).
- 2 outputs dedicated to control of sounders.
- Output to fire alarm routing equipment.
- Output to fault warning routing equipment.
- Signal delay at the outputs.
- Extended control panel and system testing functions.
- Communication bus to enable connection of:
 - a repeater panel;
 - the CSP-ETH module for communication with the virtual panel.
- Power output 24 V.
- Dedicated output for power supply of the CSP-ETH module.

- 4 (CSP-104 and CSP-204) or 8 (CSP-108 and CSP-208) programmable relay outputs.
- LED indicators of the status of fire alarm control panel and external devices.
- Built-in sounder.
- LCD display (CSP-204 and CSP-208).
- Real-time clock with a battery backup.
- Alarm log for up to 9999 alarms.
- Non-volatile memory of 8999 events (including alarms).
- Programming by means of:
 - buttons available on the front panel of fire alarm control panel,
 - computer with the DCSP program installed (communication through RS-232 port).
- Switching-mode power supply, output current 2.5 A.
- Automatic switchover to backup power supply (battery) in the event of main power supply failure.

4. Description of the control panels

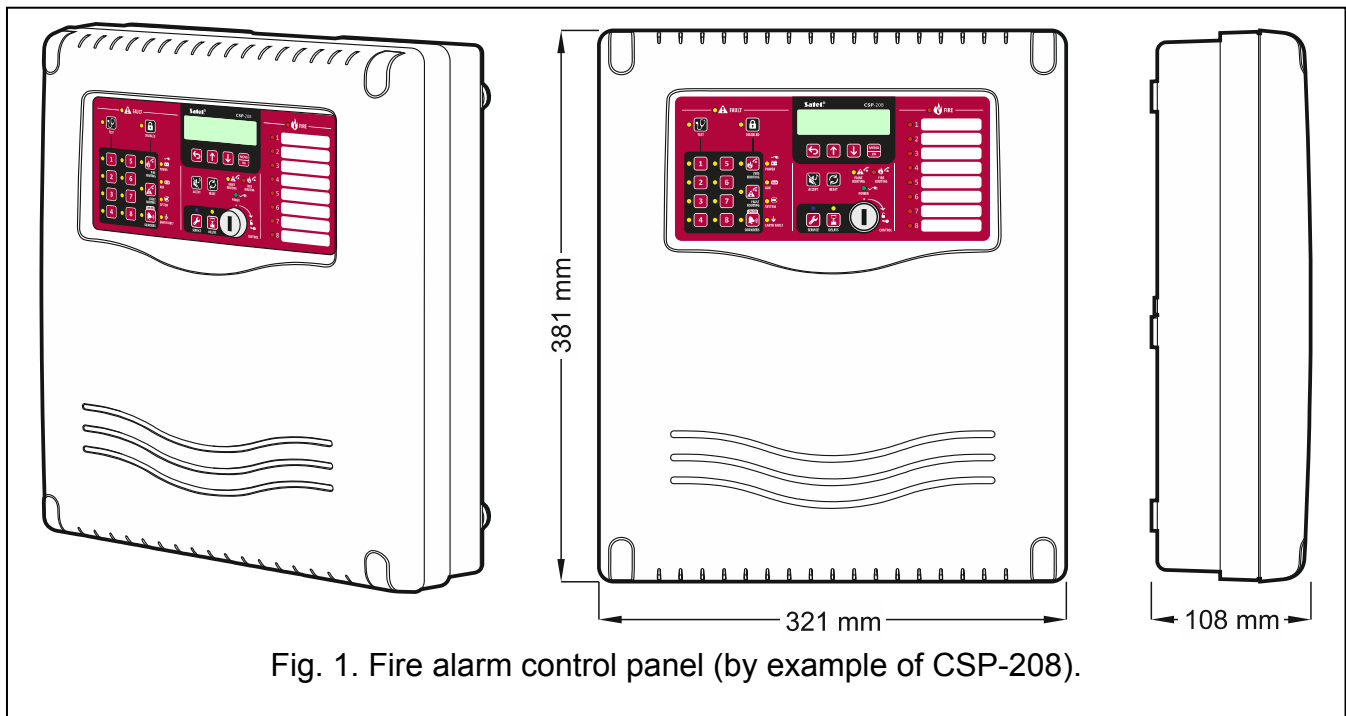

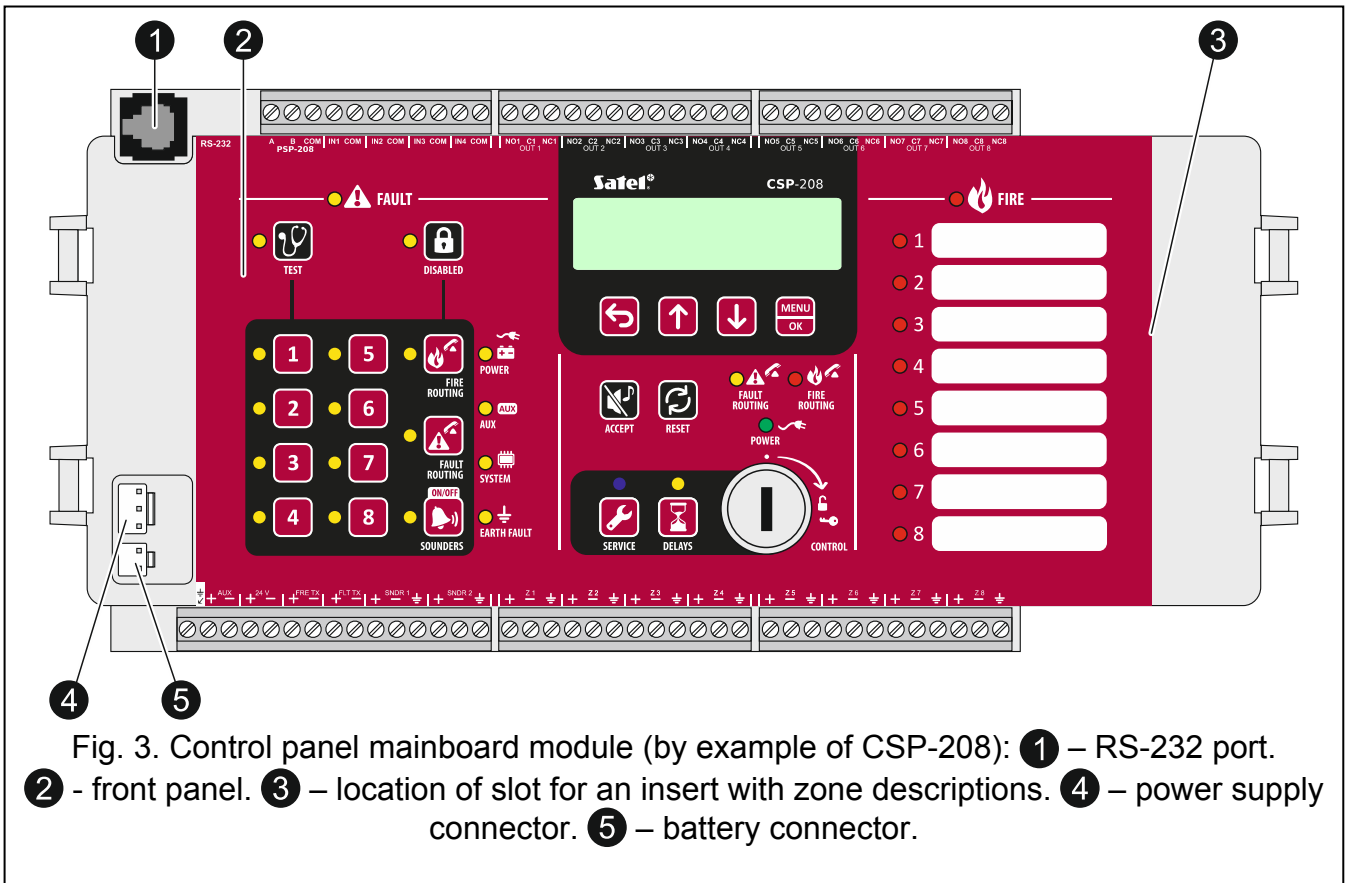
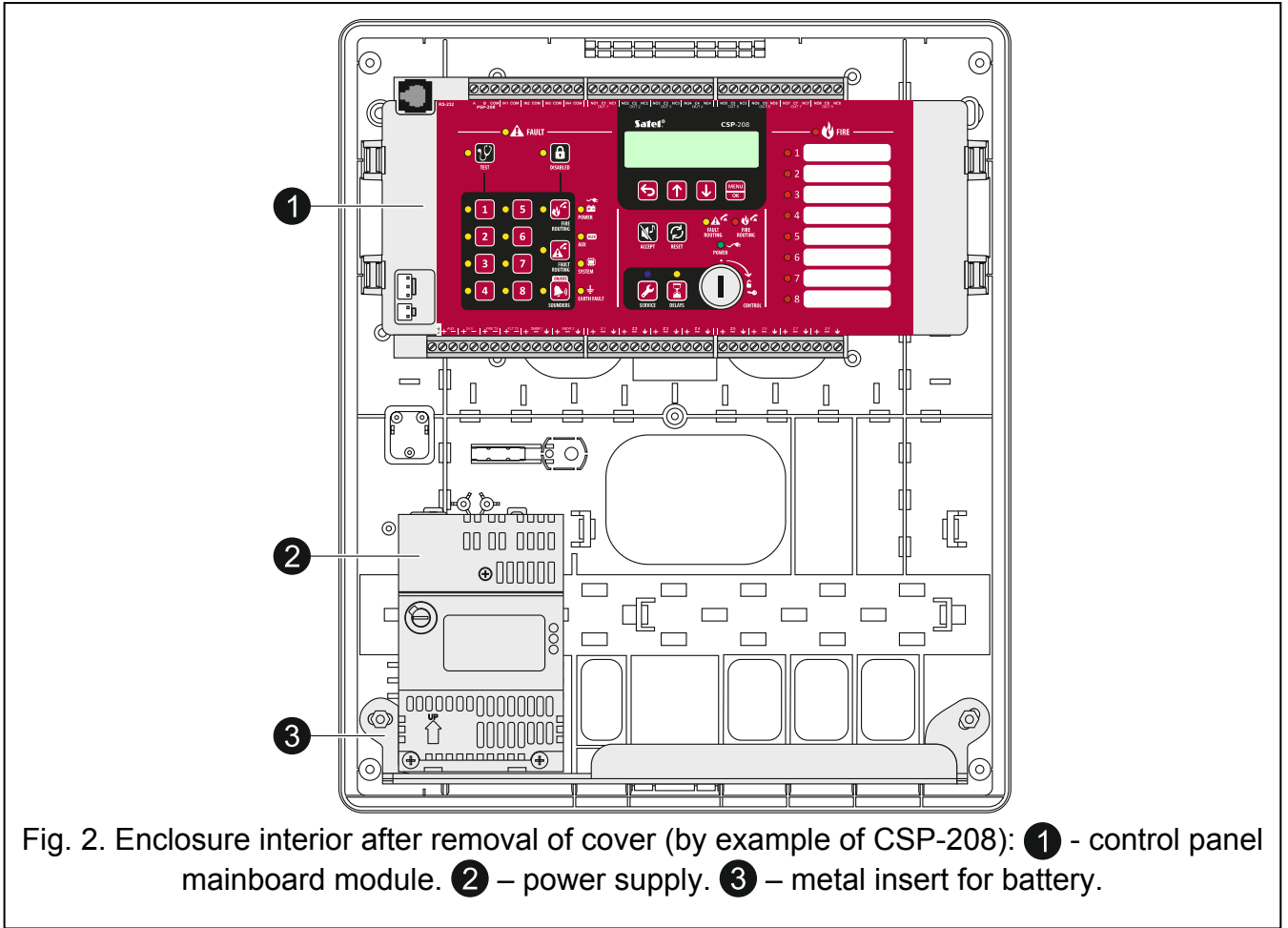

4.1 Terminals

-  - protection terminal.
- AUX** - dedicated output for power supply of CSP-ETH module (two terminals with indicated polarity).
- 24 V** - power output 24 V (two terminals with indicated polarity).
- FIRE TX** - fire alarm routing output (two terminals with indicated polarity).
- FLT TX** - fault warning routing output (two terminals with indicated polarity).
- SNDR x** - outputs for control of sounders (three terminals for each output) [x – sounder number].
- Zx** - zones (three terminals for each zone) [x – zone number].
- A, B** - communication bus terminals.
- COM** - common ground.
- INx** - programmable inputs [x – input number].
- NOx** - normally open terminal of relay output [x – output number].
- Cx** - common terminal of relay output [x – output number].
- NCx** - normally closed terminal of relay output [x – output number].

4.2 Front panel

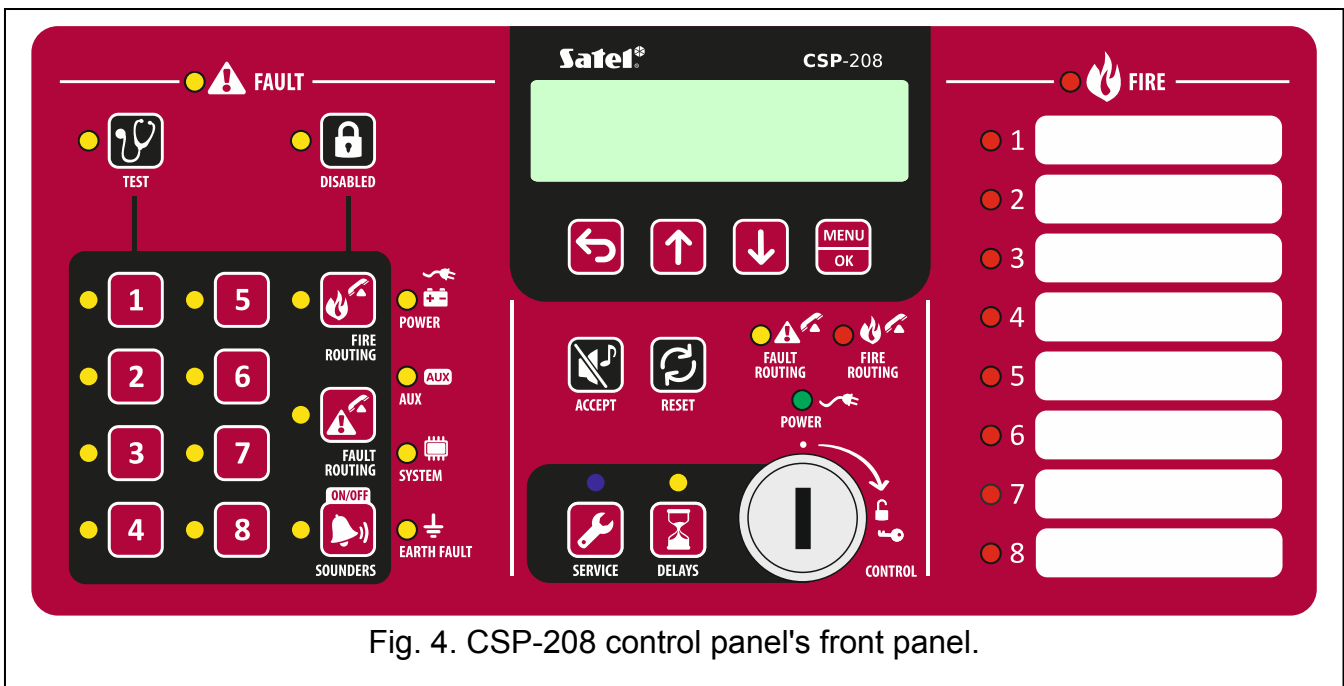

Fig. 4. CSP-208 control panel's front panel.

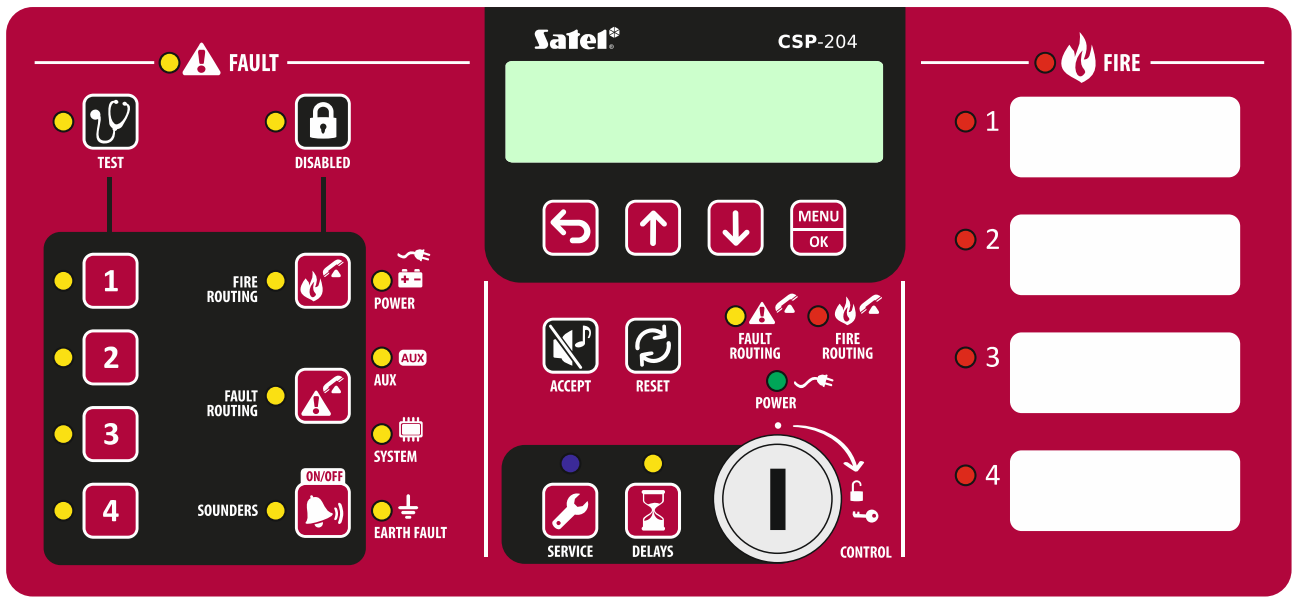

Fig. 5. CSP-204 control panel's front panel.

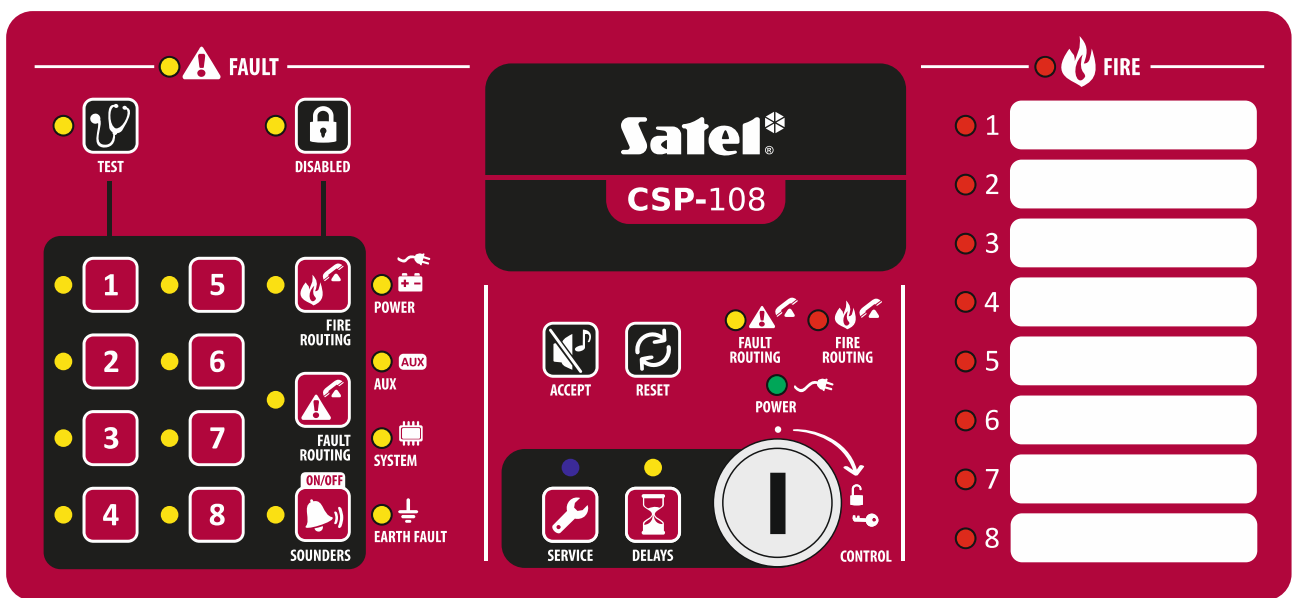

Fig. 6. CSP-108 control panel's front panel.

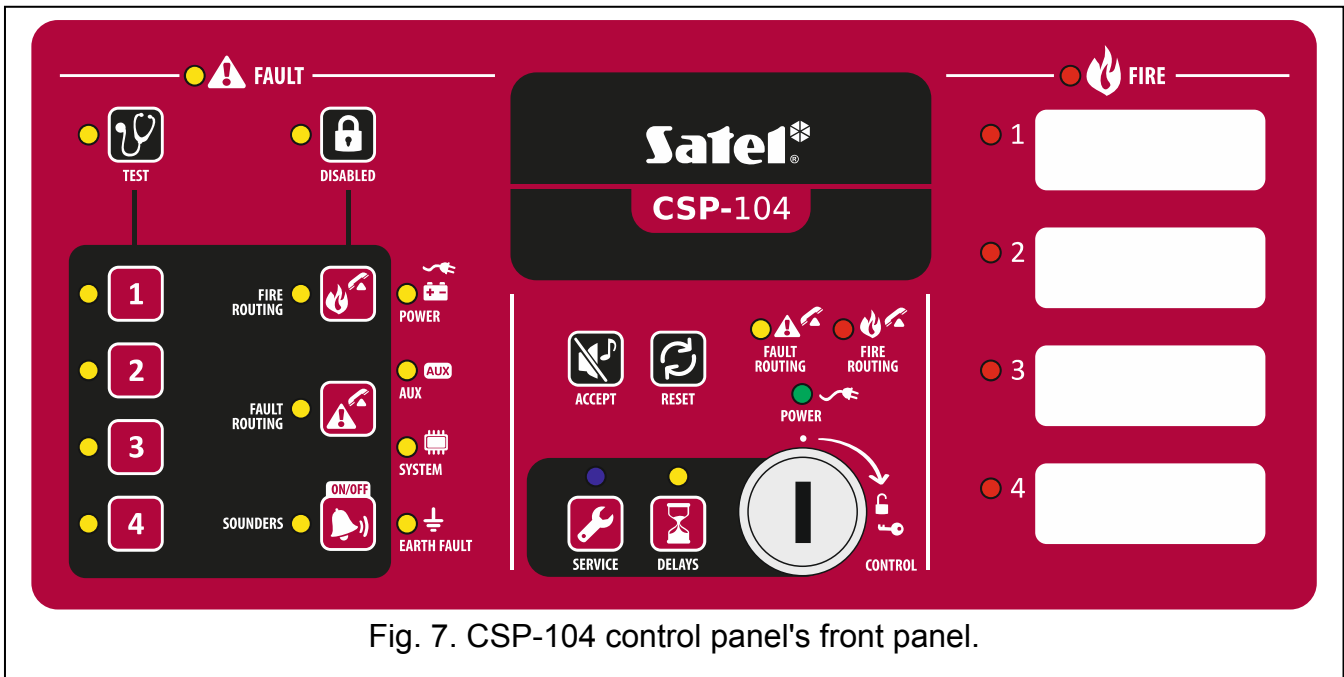





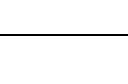





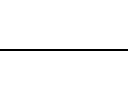

































Fig. 7. CSP-104 control panel's front panel.







4.2.1 LED indicators

LED	Description	Color	Indications
	fault	yellow	ON – fault blinking – fault memory
	test	yellow	blinking – test function is activated ON – test of zones, sounders, fire alarm routing output or fault warning routing output is running
	disabled	yellow	blinking – disablement function is activated ON – zones, sounders, fire alarm routing output or fault warning routing output are disabled
	zone 1	yellow	blinking – zone fault (short-circuit or break) ON – zone is disabled or is being tested
	zone 2		
	zone 3		
	zone 4		
	zone 5		
	zone 6		
	zone 7		
	zone 8		
	fire routing	yellow	blinking – output fault (short-circuit or break) ON – output is disabled or is being tested

	fault routing	yellow	blinking – output fault (short-circuit or break) ON – output is disabled or is being tested
	sounders	yellow	blinking – sounder fault (short-circuit or break) ON – sounders are disabled or are being tested
	power	yellow	blinking – power supply failure (loss of 230 V AC mains, missing battery, low battery, high battery resistance)
	auxiliary devices	yellow	blinking – programmable input fault (short-circuit or break), fault signaled by a device connected to programmable input, power output fault (overload), repeater panel or CSP-ETH module not present, repeater panel fault
	system	yellow	blinking – control panel hardware fault, microprocessor-based system fault, corrupted data in control panel memory, or alarm log overflow
	earth fault	yellow	blinking – earth fault in one of the circuits of fire alarm system
	fault routing	yellow	blinking – fault warning routing output is active (no confirmation of transmission) ON – fault warning routing output is active and transmission is confirmed
	fire routing	red	blinking – fire alarm routing output is active (no confirmation of transmission) ON – fire alarm routing output is active and transmission is confirmed
	power	green	ON – control panel is supplied from 230 V AC mains blinking – control panel is supplied from a battery (no 230 V AC supply)
	service	blue	slow blinking – access level 2 fast blinking – waiting for code entry after the  key is pressed ON – access level 3 (programming)
	delays	yellow	ON – two-stage alarm mode is enabled (second stage alarm is delayed)
	fire	red	blinking – fire alarm ON – fire alarm acknowledged by the operator
	fire in zone 1	red	slow blinking – pre-alarm fast blinking – first alarm ON – next alarm
	fire in zone 2		
	fire in zone 3		
	fire in zone 4		
	fire in zone 5		
	fire in zone 6		
	fire in zone 7		
	fire in zone 8		

4.2.2 Buttons

Button	Access level	Function
	1	- starts the test of LED indicators and built-in sounder of control panel / repeater panel
	2	- starts the function of testing zones, sounders, fire alarm routing output or fault warning routing output
	3	- allows to check the function number [CSP-104 and CSP-108 panels only]
	2	- starts the function of disabling zones, sounders, fire alarm routing output or fault warning routing output
	3	- allows to check the data programmed in the control panel [CSP-104 and CSP-108 panels only]
	2	<ul style="list-style-type: none"> - after pressing the  button – disables / enables the zone - after pressing the  button – starts / stops the zone test - after pressing the  button – the buttons 1-4 allow to enter the level 3 access code (programming)
		
		
		
		
		
		
		
	2	<ul style="list-style-type: none"> - after pressing the  button – disables / enables the fire alarm routing output - after pressing the  button – starts a test of the fire alarm routing output
	2	<ul style="list-style-type: none"> - after pressing the  button – disables / enables the fault warning routing output - after pressing the  button – starts test of the fault warning routing output
	2	<ul style="list-style-type: none"> - deactivates / activates sounders during a fire alarm - after pressing the  button – disables / enables the sounders - after pressing the  button – starts a test of the sounders
	1 or 2	<ul style="list-style-type: none"> - acknowledges the alarm or fault warning and silences the acoustic signaling in control panel and repeater panel - resets the fault memory

	2	- resets the fire alarm - resets the fault
	3	- exits the function [only CSP-104 and CSP-108 panels]
	2	- activates / deactivates two-stage alarm mode (second stage alarm delay)
	1	- allows to check whether level 2 operation is available on the repeater panel
	2	- allows to gain level 3 access (control panel programming)
Only for CSP-204 and CSP-208 control panels		
	1 or 2	- exits the menu, submenu or function and allows to perform other operations in the user menu
	3	- exits the submenu or function and allows to perform other operations in the programming menu
	1 or 2	- scrolls up and allows to perform other operations in the user menu
	3	- scrolls up and allows to perform other operations in the programming menu
	1 or 2	- scrolls down and allows to perform other operations in the user menu
	3	- scrolls down and allows to perform other operations in the programming menu
	1 or 2	- opens the user menu - enters submenus or starts functions, and allows to perform other operations in the user menu
	3	- enters submenus or starts functions, and allows to perform other operations in the programming menu

4.2.3 Key switch

The key switch allows to gain access at level 2 and 3 (see: ACCESS LEVELS, p. 18).

4.2.4 Display

The CSP-204 and CSP-208 control panels come with a display installed. It allows to view the alarm and event logs and to better identify the current faults, as well as facilitates programming the control panel.

5. Installation of the control panel



Disconnect power before making any electrical connections.

5.1 Mounting the control panel

The control panel should be installed indoors, in spaces where temperature does not drop below -5° and does not exceed 40° , and the relative humidity of air is maximum 93% (without condensation).

The mounting location should be readily accessible for operation and servicing and should provide good visibility of the LED indicators and legibility of markings on the front panel. A power supply circuit with protective grounding should be available at the control panel mounting location. The control panel should be power supplied from a separate power circuit, protected by a circuit-breaker with characteristics and current rating matched to suit the

control panel needs. This circuit should meet the existing standard requirements for low-voltage electrical installations.

1. Remove 4 screw caps from the cover.

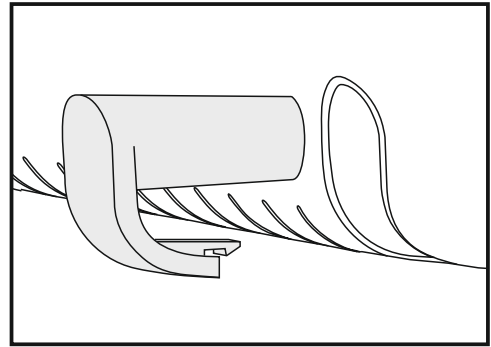

2. Remove 4 screws fixing the cover.

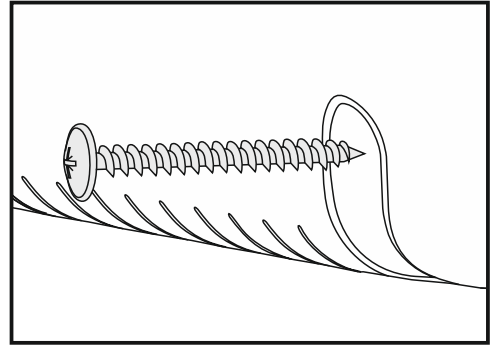

3. Remove the cover.

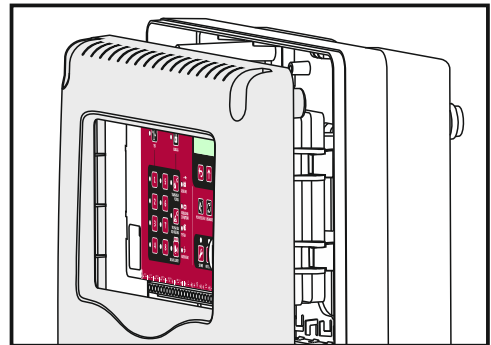

4. Remove the control panel mainboard module from its mountings.

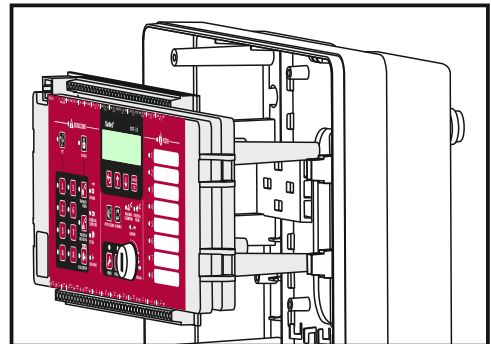

5. Remove 2 bolts locking for transport the insert for battery.

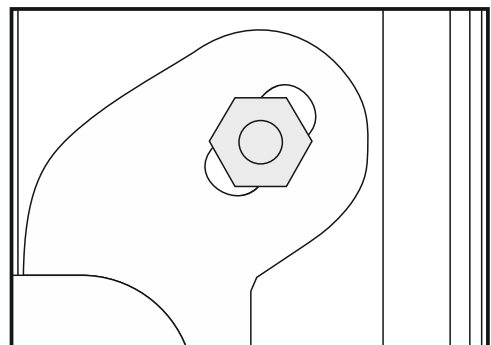

6. Put the enclosure base against the wall at the place where the control panel is to be installed, and mark the location of 4 enclosure mounting holes.

7. At the marked places, drill holes for wall plugs (the wall plugs are delivered with the control panel).
8. Run the cables through the holes at the enclosure base.
9. Attach the enclosure base to the wall, using the screws delivered with the control panel.
10. Install the control panel mainboard module in its mountings inside the enclosure.
11. Install the battery.
12. Connect wires to the corresponding terminals of the control panel (see description of connecting devices and power supply hereinunder).
13. Put the insert with zone descriptions into the slot intended for this purpose. The insert template can be downloaded from the www.satel.eu website.
14. Replace the cover..
15. Secure the cover, using 4 screws.
16. Replace the screw protection caps.
17. If any installation or construction work is being carried out in the building, you should protect the control panel against dust until such work is completed.

5.2 Connections

When running cables, remember to keep a suitable distance between low-voltage wires and 230 V AC power leads. Avoid running the signal wires in parallel to the 230 V AC power leads in their immediate vicinity.

5.2.1 Zones

The CSP-108 and CSP-208 control panels have 8 zones, and the CSP-104 and CSP-204 – 4 zones. It is recommended that a screened cable be used to connect devices. For all zones, a dedicated $\overline{\text{—}}$ terminal for connecting the screen is situated next to the pair of terminals with their polarity indicated.

The zone circuit should be terminated with a 5.6 k Ω resistor (the resistor can be screwed to the terminals of the last device in the circuit). If the zone is not used, the resistor should be screwed directly to the zone terminals.

Note: Do not connect the detectors and manual call points (MCPs) to the same zone.

Connecting the detectors

The total number of detectors connected to a zone must not exceed 32.

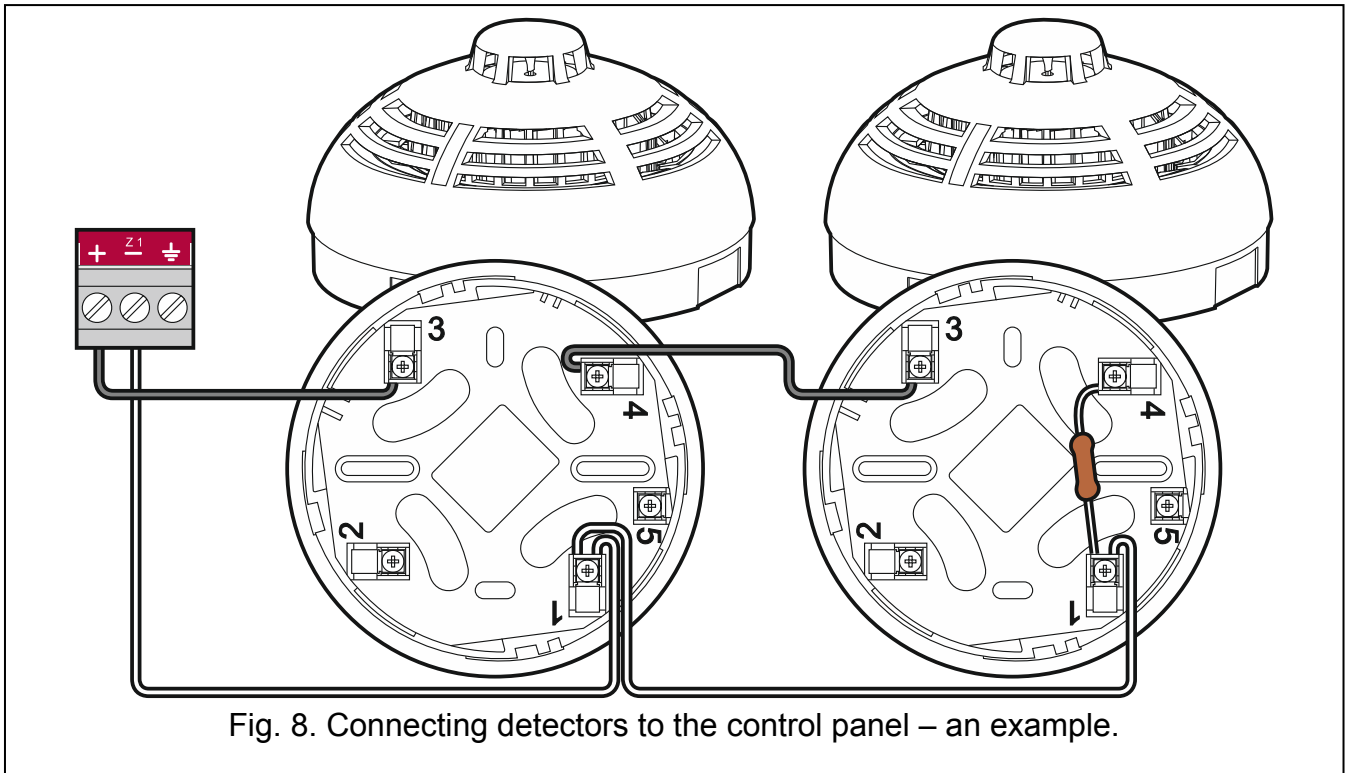

Fig. 8. Connecting detectors to the control panel – an example.

Connecting the manual call points (MCPs)

The total number of MCPs connected to a zone must not exceed 10.

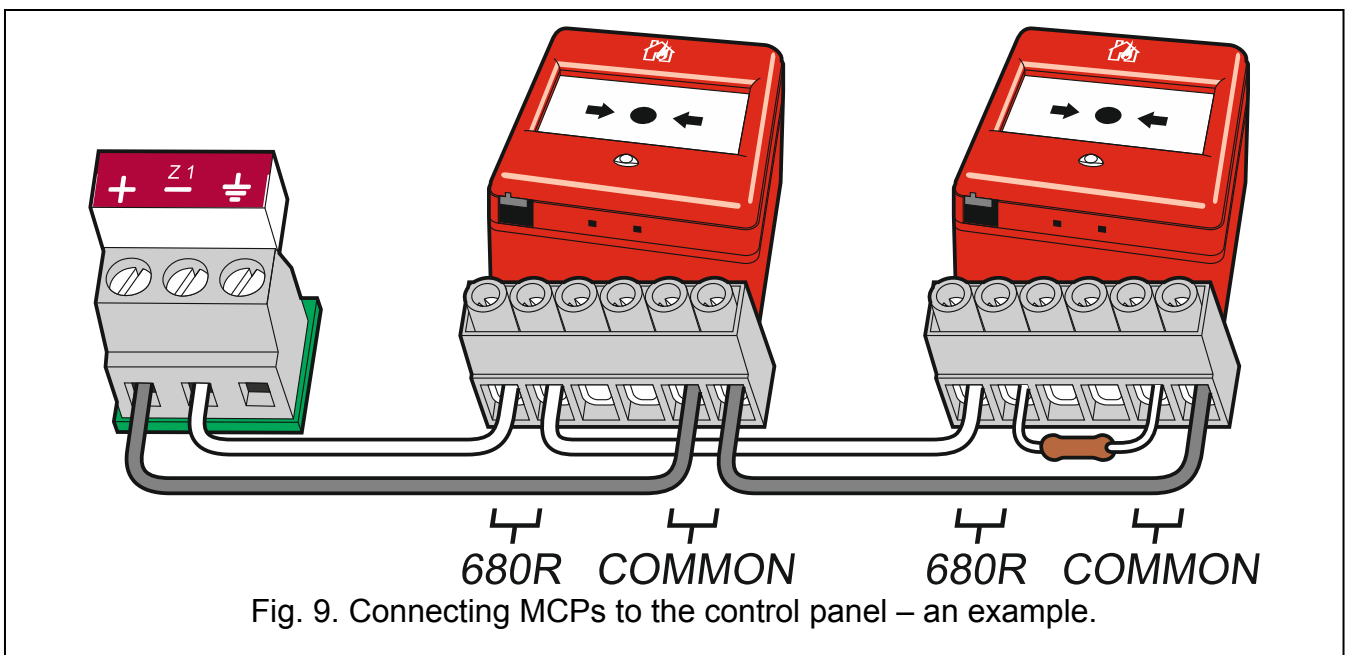

Fig. 9. Connecting MCPs to the control panel – an example.

5.2.2 Programmable inputs

The fire alarm control panel has 4 programmable inputs. They allow to monitor the status of external devices provided with an NC relay. Using the screened cable for connection of the devices to the programmable inputs is not required. The circuit should be terminated with a 10 kΩ resistor (the resistor can be screwed to the terminals of the last device in the circuit). An 1 kΩ resistor must be connected in parallel with the relay (see: Fig. 10). The control panel program makes it possible to deactivate each input, if it is not to be used (if so, screwing the resistor to the terminals is not required).

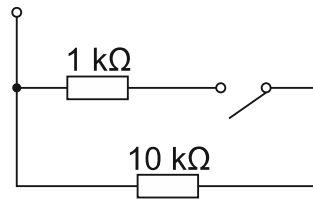

Fig. 10. The way of connecting resistors in the case of programmable input circuit.

5.2.3 Sounders

The fire alarm control panel comes with two sounder outputs. It is not required to use the screened cable for connection of the sounders. For both outputs, a dedicated \perp terminal for connecting the screen is situated next to the pair of terminals with their polarity indicated.

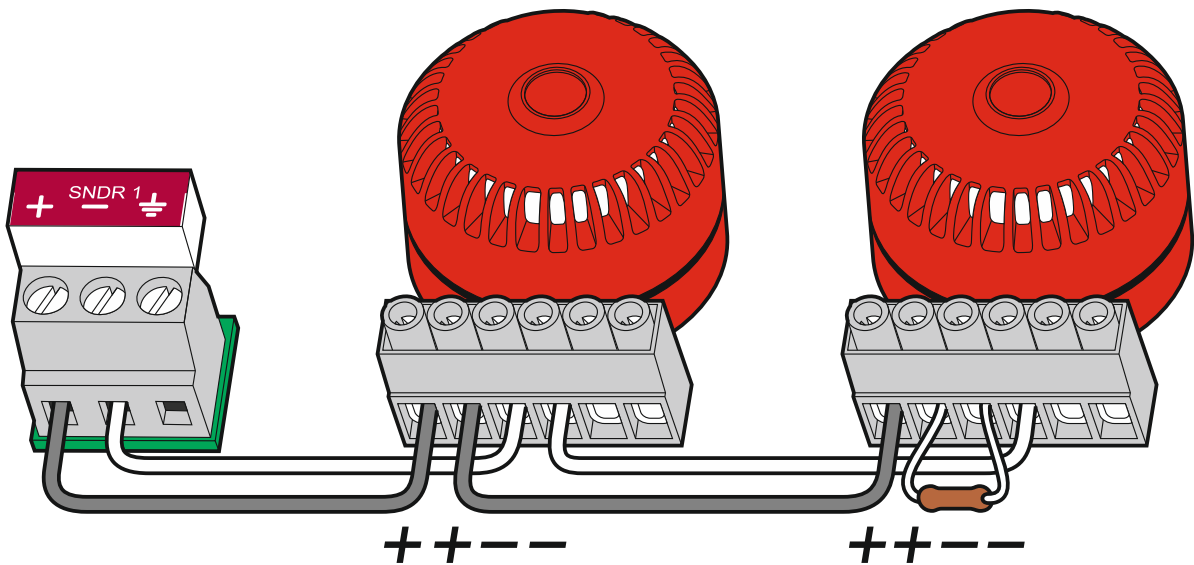

Fig. 11. Connecting sounders to the control panel – an example.

The sounder circuit should be terminated with a 10 kΩ resistor (the resistor can be screwed to the terminals of the last sounder in the circuit). If the output is not used, the resistor should be screwed directly to the output terminals.

5.2.4 Outputs to the routing equipment

The control panel is provided with an output to the fire alarm routing equipment and an output to the fault warning routing equipment. Using the screened cable for making the connections is not required. The circuit should be terminated with a 10 kΩ resistor. If the output is not used, the resistor should be screwed directly to the output terminals. The control panel program makes it possible to deactivate one or both outputs, if they are not in use (if so, screwing the resistor to the terminals is not required).

5.2.5 Relay outputs

The CSP-108 and CSP-208 control panels have 8 relay outputs each, and the CSP-104 and CSP-204 control panels – 4 outputs. The relay outputs can control external devices.

5.2.6 Power outputs

The control panel is provided with two power outputs. The output marked AUX is a dedicated power supply output for the CSP-ETH module. The output marked 24 V can be used to power the external devices which require 24 V DC voltage supply. The output can only be used during an alarm.

5.2.7 Communication bus

The communication bus connecting the control panel, repeater panel and CSP-ETH module should be made with the use of UTP type cable (unscreened twisted pair). One pair of wires should be used for data transmission (terminals A and B), and the other wires should be connected to the COM terminal. The communication bus length can be up to 1000 meters. At the beginning and at the end, the communication bus should be loaded with 100 Ω resistors.

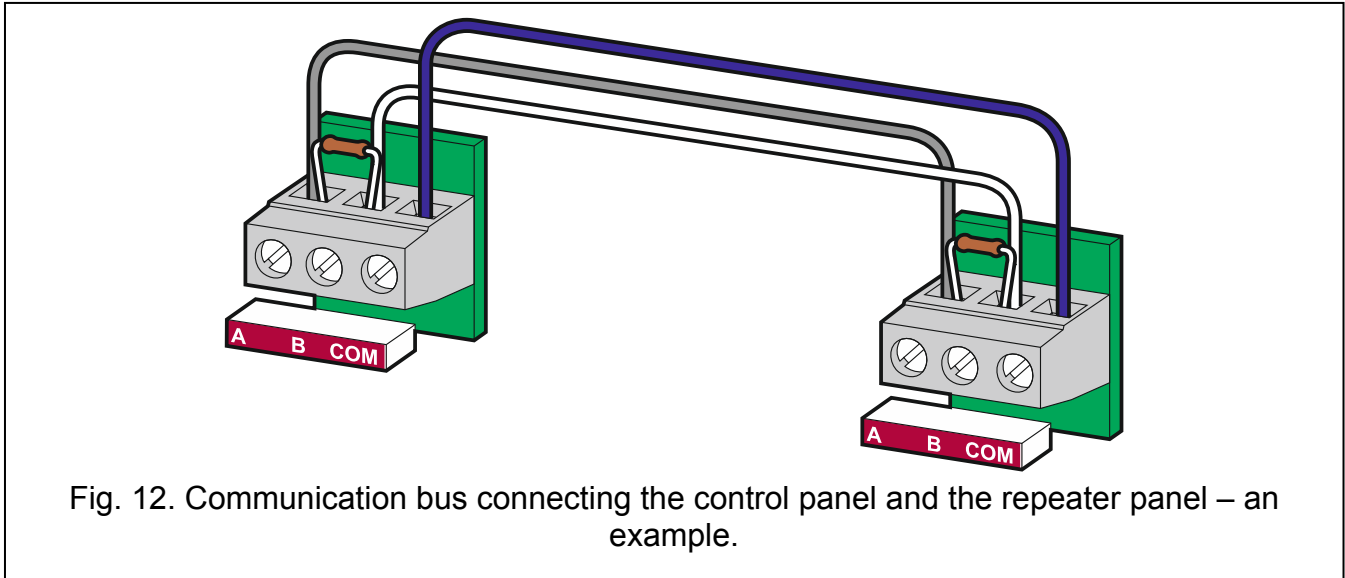

5.2.8 Main power supply

The main power source is 230 V AC / 50 Hz electric system. The control panel power supply unit should be connected to an unswitched 230 V AC power circuit.



Before connecting the power supply unit to a 230 V AC circuit, the circuit must be de-energized.

1. Remove the screw fixing the cover of power supply terminals.

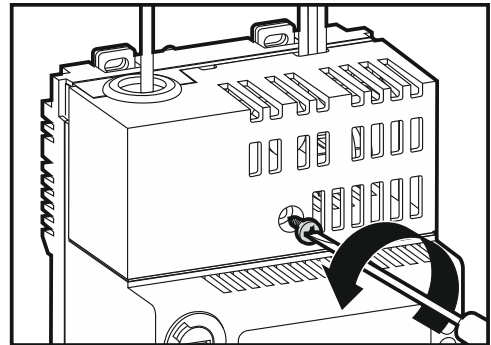

2. Remove the cover of power supply terminals.

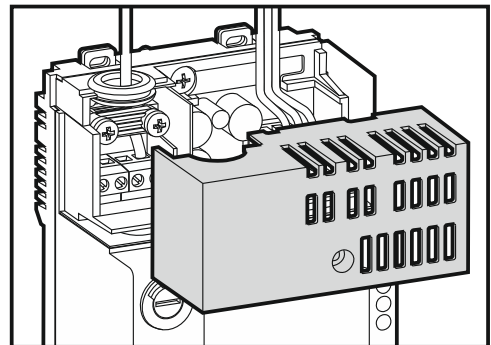

3. Remove the screws and take out the wire fastening element.

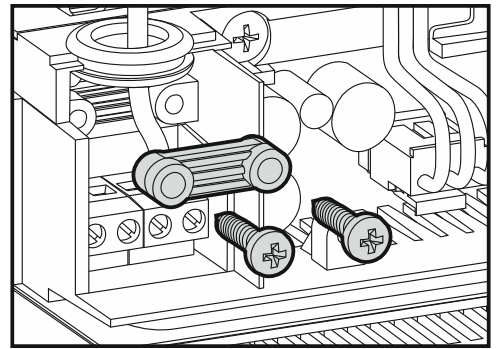

4. Run the cable through the cable entry.

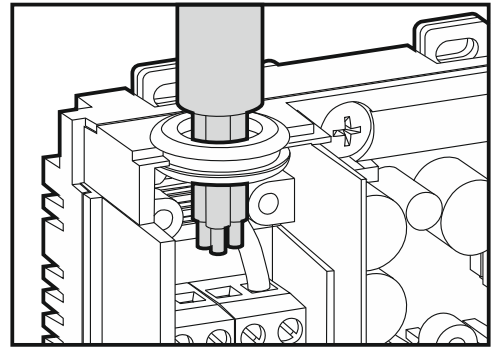

5. Screw the 230 V AC power leads to the corresponding terminals (phase conductor to L terminal, neutral conductor to N terminal, and protective conductor to PE terminal).

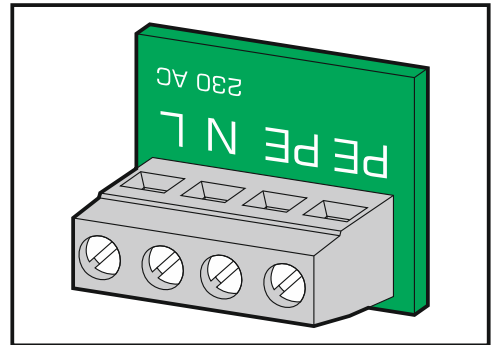

6. Screw the wire fastening element.

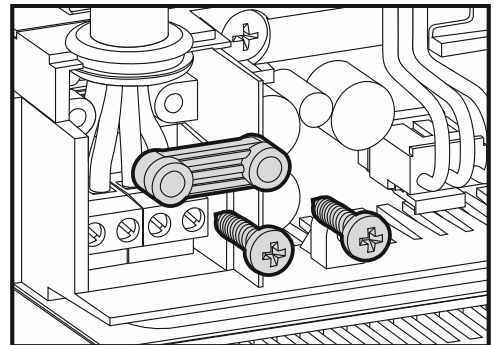

7. Replace the cover of power supply terminals.

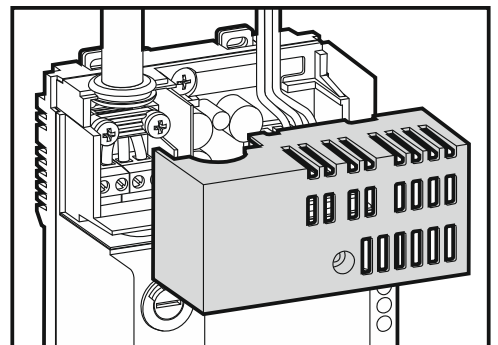

8. Screw in the screw fixing the cover of power supply terminals.

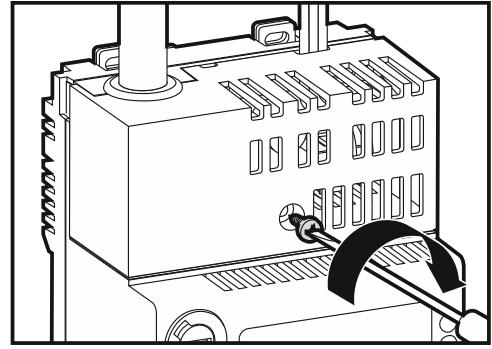

5.2.9 Backup power supply

A 12 V sealed lead-acid battery should be used as the backup power source. A battery of max. 17 Ah capacity can be installed in the control panel enclosure. The control panel can be used with up to 24 Ah capacity battery (in an external battery box).









The battery must be connected to the dedicated leads (positive terminal to RED lead, negative terminal to BLACK lead).

If the battery voltage drops under load below 11.5 V, the control panel will signal a battery fault. When the voltage drops to approx. 10.5 V, the battery will be disconnected.

6. Access levels

The control panel offers three access levels, at which different functions are available. On the repeater panel, only levels 1 and 2 are available.

6.1 Level 1 – all users

The ,  and  buttons [control panel] or the  button [repeater panel] can be used. In the case of control panels and repeater panels equipped with LCD display, the , ,  and  buttons are also available, which allow to open and use the user menu (the clock programming is not available).

6.2 Level 2 – authorized users



All buttons are available for use. In order to get access at level 2, turn the key switch to position marked with the  symbol.

Note: *The control panel cannot be operated at the level 2 at the same time from the control panel and from the repeaters panel, hence:*

- *turning the control panel key switch will always result in getting access at level 2 (access level 2 on the repeater panel is automatically exited);*
- *getting access at level 2 from the repeater panel is impossible, if operation at level 2 is available on the control panel.*

6.3 Level 3 – control panel programming

In order to get access at level 3, turn the key switch to position marked with the  symbol, and then:

1. Press the  button. The blue LED above the button will start blinking fast.
2. Enter the code, using the buttons marked with digits from 1 to 4 (**serial code: 1234**).
3. Press the  button. The blue LED above the button will come on steady.

Notes:

- If any of the LEDs indicating zone fire is blinking or on, getting access at level 3 is impossible.
- When the control panel is being programmed, it does not perform other functions (the repeater panel is not supported, alarms and/or faults are not signaled, etc.).

7. Programming

Programming the control panel is possible after getting access at level 3. You can configure the control panel using the buttons available on the front panel, or by means of the DCSP program.

7.1 Description of functions, parameters and options

7.1.1 Zone parameters

Name – individual name of zone (up to 10 characters).

Alarm mode:

one-stage – detector activation will trigger second stage alarm (main alarm);

two-stage – detector activation will trigger first stage alarm (internal alarm of the control panel – the fire alarm routing output will not be activated). If the operating personnel fails to acknowledge the alarm within 30 seconds, second stage alarm will be triggered. If the operating personnel acknowledges the alarm, second stage alarm will be delayed by the preset VERIFICATION TIME (see: **Global settings**). The alarm will be a two-stage one, if the two-stage alarm mode is enabled by the operator (second stage alarm delay)

using the  button. Otherwise, detector activation will trigger second stage alarm immediately.

Dependency:

independent – activation of the detector or the manual call point in the zone will trigger alarm.

type A dependency – after detector activation, the control panel will not signal the alarm, which is preliminarily reset. If another detector in the same zone is activated within 60 seconds, the alarm will be triggered.

type B dependency – detector activation will trigger a pre-alarm (the red LED with the zone number will start blinking or will be on, and acoustic signaling will be set off). The alarm will be triggered, if within 30 minutes of that moment any detector is activated in the dependent zone. If the alarm is not triggered, the pre-alarm will be automatically reset.

Dependent zones – in case of the type B dependency, the dependent zones must be indicated. You can indicate the same zone or another type B dependent zone.

Note: *The zones to which MCPs are connected must trigger second stage alarm at once (one-stage alarm mode without coincidence detection).*

7.1.2 Sounder parameters

Alarm II – second stage alarms are signaled.

Alarm I or II – first stage and second stage alarms are signaled.

Alarm I (p) or II – first stage and second stage alarms are signaled, but for first stage alarms, voltage is supplied in pulse mode.

7.1.3 Routing outputs

You can permanently disable the fire alarm routing output and the fault routing output. The control panel does not control the output if permanently disabled, its status is not supervised, it cannot be tested or disabled by operator.

7.1.4 Input parameters

Name – individual name of input (up to 10 characters).

Input type:

Disabled – the input status is not monitored.

Fire damper – supervises the fire damper (in quiescent condition, a fault warning will be triggered by activation; in fire alarm condition, a fault warning will be triggered by lack of activation).

Auxiliary device fault – supervises operation of the external devices (activation will trigger a fault warning).

Transmission confirmation – activation is treated as transmission receipt confirmation.

Class change – activation triggers the sounders.

Options – for the TRANSMISSION CONFIRMATION input type, you should specify which transmissions will be confirmed: fire, fault, or both.

Delay time – depending on the input type:

FIRE DAMPER – time during which the input must be active in the quiescent condition or inactive in the fire alarm condition for the fault to be indicated.

AUXILIARY DEVICE FAULT – time during which the input must be active for the fault to be indicated.

TRANSMISSION CONFIRMATION – time counted from the moment of activating the fire routing output or fault routing output. After the time has elapsed, a fault will be indicated, if the transmission receipt is not confirmed.

Note: *If several inputs have been programmed as TRANSMISSION CONFIRMATION and they have different DELAY TIME values programmed, the control panel will indicate the fault after the shortest delay time has elapsed.*

CLASS CHANGE – if value 0 is programmed, the sounders will be activated when the input is active. If a different value is programmed, the sounders will be activated for a programmed time after the input is activated.

7.1.5 Output parameters

Name – individual name of output (up to 10 characters).

Output type:

Disabled – the output is not used.

Alarm I – indicates a first stage alarm condition in the selected zones.

Alarm II – indicates a second stage alarm condition in the selected zones.

Alarm I or II – indicates a first or second stage alarm condition in the selected zones.

No transmission confirmation – indicates lack of transmission confirmation.

General fault – indicates any fault condition.

Zone fault – indicates selected zone fault condition.

Other fault – indicates selected faults.

General disablement – indicates disablement of any component of the control panel.

Zone disablement – indicates disablement of the selected zones.

Other disablement – indicates selected disablements.

Reset – indicates reset of alarm or fault warning.

Options – depending on the output type:

ALARM I / ALARM II / ALARM I OR II / ZONE FAULT / ZONE DISABLEMENT – select the zones in which occurrence of the given event will activate the output.

OTHER FAULT – select which faults are to be indicated by the output.

OTHER DISABLEMENT – select which disablement are to be indicated by the output.

Delay time – the time during which the given condition (alarm, fault, disablement) must last for the relay to be activated. You can program up to 10 minutes.

Cut off time – the time during which the relay is active. You can program up to 10 minutes. If value 0 is programmed, the relay will remain active as long as the state indicated by the output continues (1 second for the RESET type outputs).

7.1.6 Earth fault monitoring

The DCSP program allows you to disable the earth fault monitoring function. When the earth fault monitoring is disabled, the control panel does not indicate any earth faults.

7.1.7 Global settings

Verification time – time counted from the moment of alarm acknowledgement by the operator (two-stage alarm mode). It allows the operator to assess the reality of danger. After the verification time has elapsed, second stage alarm will be triggered, unless the operator resets the alarm. You can program up to 9 minutes 30 seconds.

Automatic sounder restore – if this option is enabled, the alarm will always activate the sounders (if the operator have deactivated the sounders using the  button, they will be activated).

Clock:

Time set – time programming.

Date set – date programming.

Clock correction – if the accuracy of control panel clock is inadequate, the clock settings can be automatically corrected once in 24 hours by a defined time. The correction time is programmed in seconds.

DST – the control panel clock can be adjusted for daylight saving time changes. The following schedules are available:

- no correction;
- according to European Union rules;
- according to US rules;
- correction by 1 hour according to dates;
- correction by 2 hours according to dates.

Time zone – the time zone in which the control panel operates, i.e. the difference between the universal time (GMT) and the zone time. The parameter is used by the control panel during the time change according to the European Union / United States rules.

DST from / DST to – if the control panel clock is to be adjusted by 1 or 2 hours according to dates, you must enter the dates (day, month), when the DST starts (clock goes forward) and ends (clock goes back).

Message – an editable message is shown in the display lower line (CSP-204 and CSP-208 control panels).

7.1.8 Panels

Repeater panel

Panel support – if a repeater panel is connected to the communication bus, the panel support should be enabled (the control panel will be monitoring presence and power supply of the repeater panel).

Panel name – individual name of the repeater panel (up to 10 characters).

Virtual panel

Panel support – if the CSP-ETH module is connected to the communication bus, the virtual panel support should be enabled (the control panel will be monitoring presence of the module).

MAC address – MAC address of the CSP-ETH module.

Password – the password which allows to log in and use the virtual panel. By default: satel.

DHCP – if the DHCP support is enabled, the module will automatically download data on IP address, subnet mask and gateway from the DHCP server.

IP address – IP address of the module. By default: 192.168.1.200. If the DHCP support is enabled, the address downloaded from DHCP server is presented (it is not editable).

Subnet mask – mask of the subnet in which the module is used. By default: 255.255.255.0. If the DHCP support is enabled, this function is not available.

Gateway – IP address of the network device through which the other devices in the local network can communicate with devices in other networks. By default: 192.168.1.1. If the DHCP support is enabled, this function is not available.

7.1.9 Code

The code allows to get access to the control panel at level 3 (see: ACCESS LEVELS p. 18). By default, the **1234** code is programmed in the control panel. The code should be changed as soon as possible. The new code may include 4 to 8 digits from the 1 to 4 range.

7.2 DCSP program

The DCSP program makes it possible to configure the fire alarm control panels and to read the alarm and event logs.

7.2.1 Connecting the control panel to computer

The connection between the RS-232 port on control panel mainboard and the computer port must be made according to Fig. 13. A ready-to-use cable is offered by SATEL as part of the DB9F/RJ-KPL set.

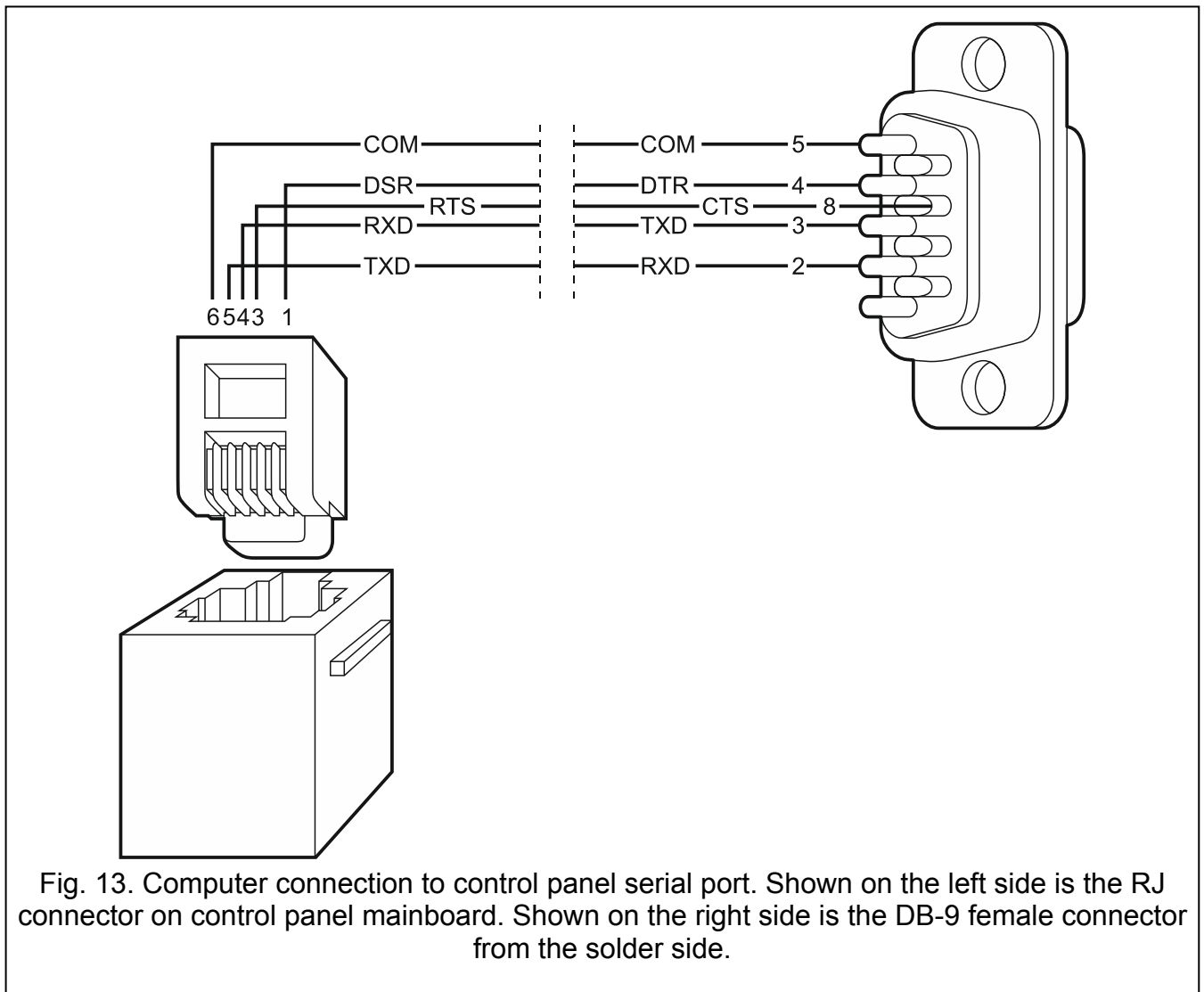

Note: It is recommended that the cable be connected first to the control panel, and then to the computer.

7.2.2 Starting the programming

1. Get level 3 access in the control panel (see: ACCESS LEVELS, p. 18). In the case of level 1 and level 2 access, the program only allows to read and view the alarm log and event log (additionally, level 2 makes it possible to program the control panel clock).
2. Run the DCSP program on the computer.



3. Click on the  button.
4. When a selection window opens, select the COM port through which communication with the control panel is to take place.
5. Click on the button "OK". The port selection window will close.
6. A pop-up window will open asking you whether the data from control panel are to be read. After the control panel data have been read, you can begin programming.

7.2.3 Program description

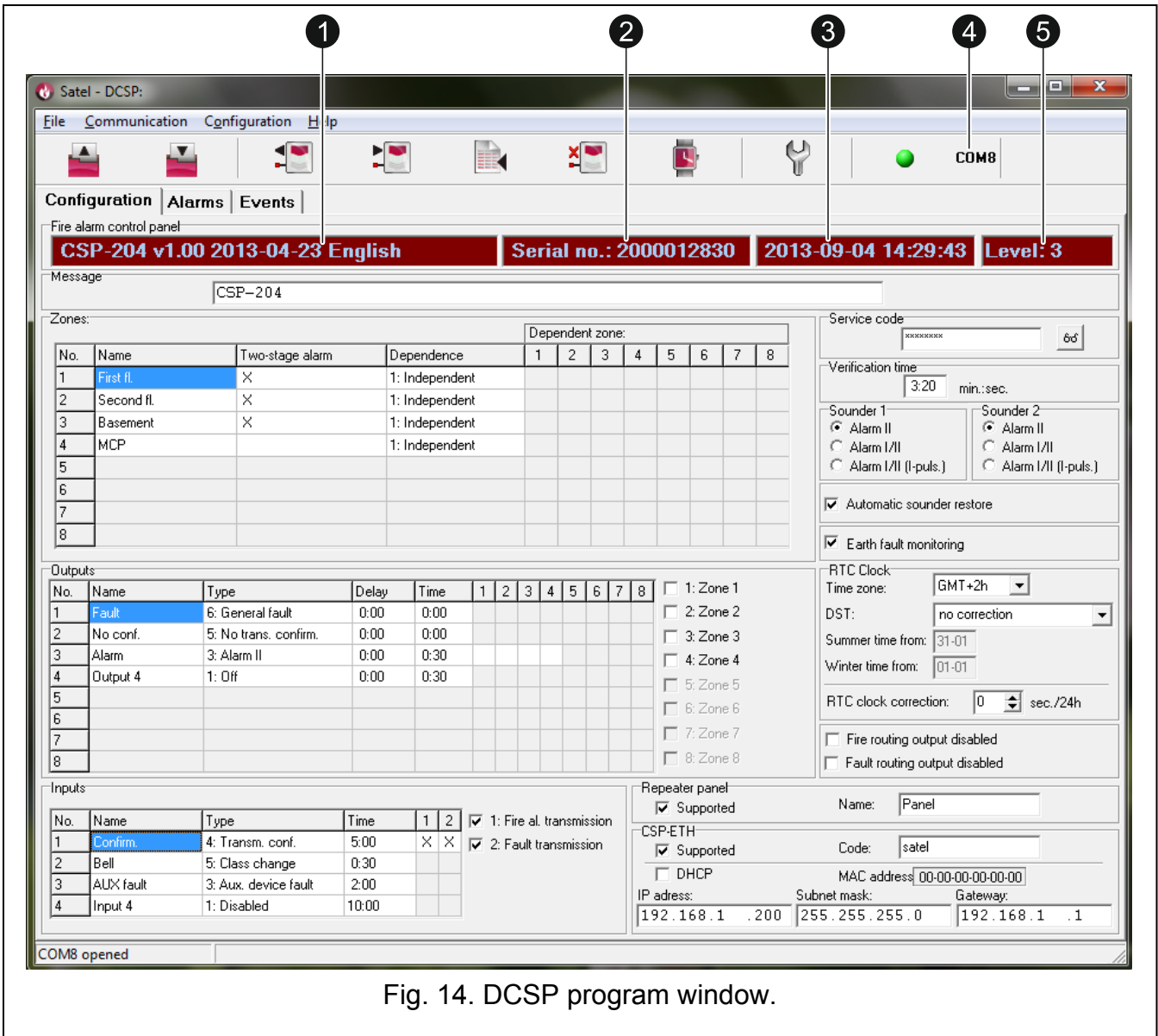

Fig. 14. DCSP program window.

- 1** the field shows the following information in the indicated order:
 - control panel type;
 - control panel firmware version number;
 - firmware build date;
 - firmware language version.
- 2** the field shows the control panel serial number.
- 3** the field shows the date and time as per the control panel clock.
- 4** number of COM port through which communication with the control panel takes place.
- 5** current access level in the control panel.

Buttons:

Reading from a file – the button reads in the data from file.



Saving to a file – the button writes the data to file.



Read – the button reads the configuration data from control panel.



Write – the button writes the configuration data to control panel.



Read alarms and events – the button reads the alarm log and event log from control panel.



Cancel – the button stops reading data.



Set RTC clock – the button allows you to write the computer time to control panel.



Serial port selection – the button opens a window where you can select the computer COM port through which communication with the control panel is to take place.



Serial port on/off – the button enables/disables the COM port selected for communication with the control panel. The color of graphic element on the button indicates the current port status:

- green – COM port enabled;
- gray – COM port disabled.

7.3 Programming with buttons

7.3.1 Beeps during programming

1 short beep – pressing button.







2 short beeps – confirmation of starting function, confirmation of making selection or acceptance of data entry.

2 long beeps – button not available or refusal to execute the command.

7.3.2 Programming the CSP-204 and CSP-208 control panels

After getting access at level 3, the programming menu will open on the display.

Navigating through the menu

Press the  button to scroll down the menu, and the  button – to scroll up. Use the  button to enter a submenu or start a function indicated by cursor. The cursor indicating submenu has the following form: , and the cursor indicating function: . Press the  button to return to the previous menu level.

Menu structure

Note: The menu is a dynamic one, i.e. some functions are only displayed when it appears from how the specific parameters of the control panel are programmed that they will be useful.

Zones

Zone n [n – zone number]
 Zone name
 Alarm mode
 Dependency
 Dependent zones

Sounders

Sounder n [n – sounder number]

Routing outputs

Fire
 Fault

Inputs

Input n [n – input number]
 Input name
 Input type
 Options
 Delay time

Outputs

Output n [n – number of relay output]
 Output name
 Output type
 Options
 Delay time
 Cut off time

Global settings

Verific time
 Auto sdr restor
 Clock
 Time set
 Date set
 Clock correctio
 DST
 Time zone
 DST from
 DST to

Message

Panels









Repeater panel
 Panel support
 Panel name
 Virtual panel
 Panel support
 MAC address
 Password

DHCP
IP address
Subnet mask
Gateway







Change code

Exit programmin



Entering names and numerical values

The flashing cursor indicates the character which is currently being edited. The  and  buttons allow you to scroll through the letters/numbers that can be entered. The  button moves the cursor to the right, and the  button – to the left. If the cursor indicates the first character to be edited, pressing the  button will exit the function. If the cursor indicates the last character, pressing the  button will exit the function. If you have made any changes, after exiting the function you will be asked whether to save changes (use the  button to go back to the function, the  button – to cancel the changes, and the  button – to save the changes).

Selecting from single selection list





The upper display line shows the function name, and the lower – the currently selected parameter. The  and  buttons allow you to scroll through the list of parameters. Pressing the  or  button will exit the function. If you have made any changes, after exiting the function you will be asked whether to save changes (use the  button to go back to the function, the  button – to cancel the changes, and the  button – to save the changes).

Selecting from multiple selection list

The upper display line shows the function name, and the lower – one of the items that can be selected. Use the  and  buttons to scroll through the list. An additional symbol is shown in the upper right corner of the display:

 – displayed item is selected;

• – displayed item is not selected.

Pressing the  button will change the currently displayed symbol to the other one. Use the  button to exit from the function. If you have made any changes, after exiting the function you will be asked whether to save changes (use the  button to go back to the function, the  button – to cancel the changes, and the  button – to save the changes).

7.3.3 Programming the CSP-104 and CSP-108 control panels

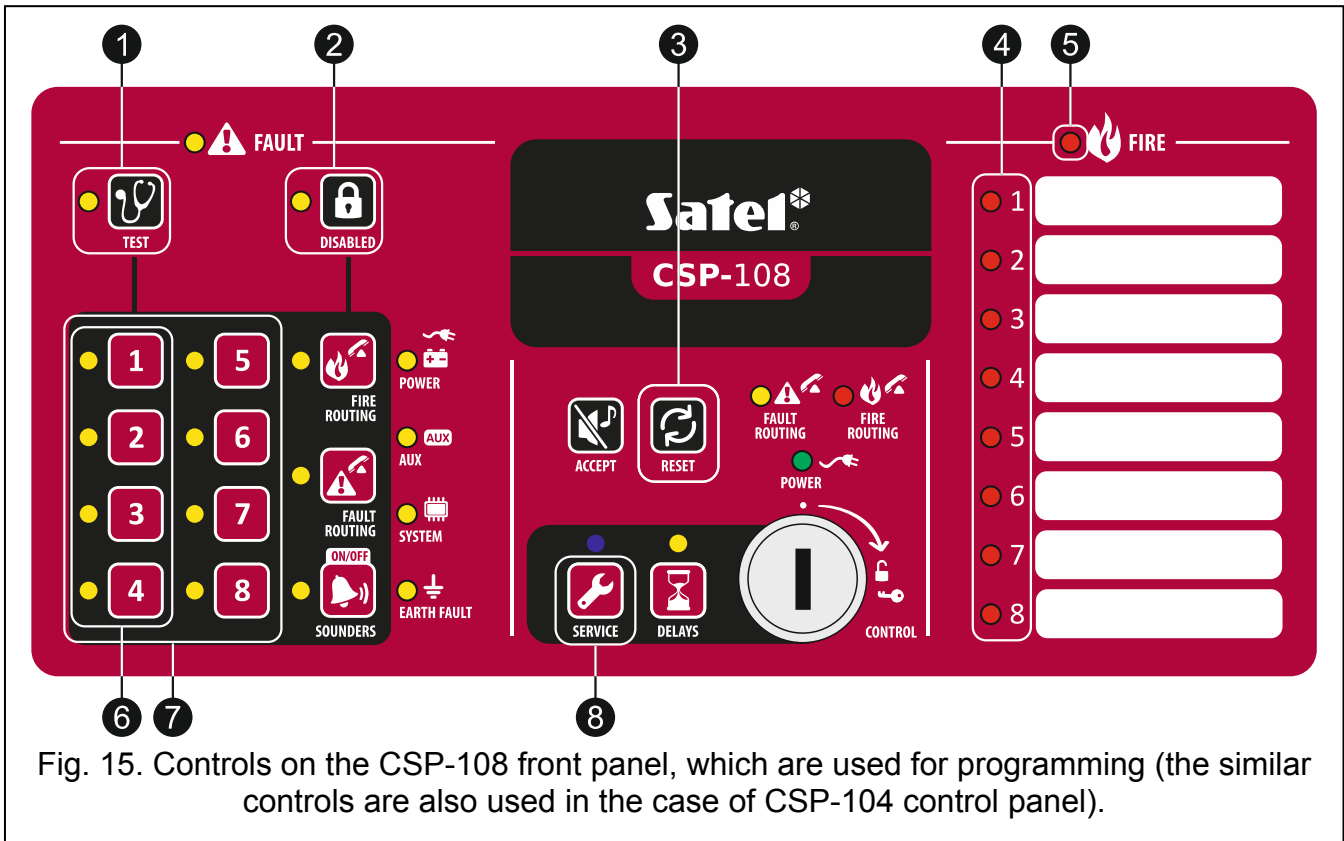





Fig. 15. Controls on the CSP-108 front panel, which are used for programming (the similar controls are also used in the case of CSP-104 control panel).



- 1 the LED next to the  button indicates that the control panel programming is in progress:
 - blinking – waiting to start the programming function;
 - ON – one of the programming functions is running. The  button allows you to check which function is running (when the button pressed, the function number is presented in binary format on the LEDs located next to the buttons 6 – see: Table 1, p. 29).
- 2 the LED next to the  button is blinking when it is possible to enter data. The  button allows you to check which data have been programmed in the control panel, irrespective of making any modifications (when the button is pressed, the data programmed in the control panel are presented on the LEDs located next to the buttons 7).
- 3 the button allows to exit the function (canceling any changes).
- 4 the LEDs present information on the currently selected zone, input, output, etc. (LED with a corresponding number is blinking or ON).
- 5 the LED informs you that one of the programming functions is running:
 - blinking – waiting for selection of zone, input, output, etc.;
 - ON – you can enter data.
- 6 the buttons allow you to select the programming function. Pressing the button makes the LED turn on / off. The function number is presented in binary format on the LEDs located next to the buttons (see: Table 1).

LED number	Function number														
	1	2	3	4	5	6	7	8	9	10	11	12	13	14	15
1	●	○	●	○	●	○	●	○	●	○	●	○	●	○	●
2	○	●	●	○	○	●	●	○	○	●	●	○	○	●	●
3	○	○	○	●	●	●	●	○	○	○	○	●	●	●	●
4	○	○	○	○	○	○	○	●	●	●	●	●	●	●	●



Table 1. The way of presenting function numbers by means of LEDs (○ - LED OFF; ● - LED ON).

- 7 the buttons allow you to select the zone, input, output, etc., and also to enter data (in the CSP-104 control panel, only four buttons are available). Pressing the button makes the LED next to the button turn ON / OFF.
- 8 the button confirms the selection made or the data entered.

1. Programming the alarm mode for zones

1. Using the buttons 6, select the function 1 (see: Table 1).
2. Press the  button.
3. Press one of the buttons 7 to select the zone for which the alarm mode will be programmed.
4. Press the  button.
5. Using the 1 and 2 button, determine the alarm mode. The ON LED indicates the selected alarm mode (only one LED can be ON):
 - 1 – one-stage;
 - 2 – two-stage.
6. Press the  button to save the changes made.

2. Programming the zone dependency (coincidence)



1. Using the buttons 6, select the function 2 (see: Table 1).
2. Press the  button.
3. Press one of the buttons 7 to select the zone for which the dependency (coincidence detection) rules will be programmed.
4. Press the  button.
5. Using the 1 and 2 buttons, determine the dependency (coincidence detection) rules.

LED number		Dependency
1	2	
●	○	independent
○	●	type A dependency
●	●	type B dependency



Table 2. Presentation of dependencies using the LEDs
(○ - LED OFF; ● - LED ON).

6. Press the  button to save the changes made.

3. Indicating the dependent zones

- Using the buttons **6**, select the function 3 (see: Table 1, p. 29).
- Press the  button.
- Press one of the buttons **7** to select the zone for which the dependent zones will be programmed.
- Press the  button.
- Using the buttons **7** indicate the dependent zones. The ON LED indicates that the zone with the given number is a dependent zone.
- Press the  button to save the changes made.

4. Programming the output type for relay outputs



- Using the buttons **6**, select the function 4 (see: Table 1, p. 29).
- Press the  button.
- Press one of the buttons **7** to select the relay output for which the output type will be programmed.
- Press the  button.
- Using the buttons **6**, specify the output type.

LED number				Output type
1	2	3	4	
●	○	○	○	disabled
○	●	○	○	alarm I
●	●	○	○	alarm II
○	○	●	○	alarm I or II
●	○	●	○	no transmission confirmation
○	●	●	○	general fault
●	●	●	○	zone fault
○	○	○	●	other fault
●	○	○	●	general disablement
○	●	○	●	zone disablement
●	●	○	●	other disablement
○	○	●	●	reset

Table 3. Presentation of output types using the LEDs (○ - LED OFF; ● - LED ON).

6. Press the  button to save the changes made.

5. Programming the options for relay outputs





1. Using the buttons **6**, select the function 5 (see: Table 1, p. 29).
2. Press the  button.
3. Press one of the buttons **7** to select the relay output for which options will be programmed.
4. Press the  button.
5. Using the buttons **7**, specify the suitable options:
 - for the outputs of ALARM I, ALARM II, ALARM I OR II, ZONE FAULT and ZONE DISABLEMENT type – the ON LEDs indicate which zones are selected;
 - for the outputs of OTHER FAULT type – the ON LEDs indicate that the following options are selected:
 - 1 – power supply fault;
 - 2 – sounder fault;
 - 3 – routing output fault;
 - 4 – other faults;
 - for the outputs of OTHER DISABLEMENT type – the ON LEDs indicate that the following options have been selected:
 - 1 – sounder disablement;

- 2 – fire routing output disablement;
- 3 – fault routing output disablement.

Note: The options are not automatically corrected when the output type changes, therefore, after starting a function or pressing the  button to check the settings saved in the control panel, the LEDs corresponding to unavailable options may turn on.

6. Press the  button to save the changes made.

6. Programming the delay time for relay outputs

1. Using the buttons , select the function 6 (see: Table 1, p. 29).
2. Press the  button.
3. Press one of the buttons  to select the relay output for which the time delay will be programmed.
4. Press the  button.
5. Using the buttons , specify the delay time.





LED number				Time
1	2	3	4	
<input type="radio"/>	<input type="radio"/>	<input type="radio"/>	<input type="radio"/>	0
<input checked="" type="radio"/>	<input type="radio"/>	<input type="radio"/>	<input type="radio"/>	30 seconds
<input type="radio"/>	<input checked="" type="radio"/>	<input type="radio"/>	<input type="radio"/>	40 seconds
<input checked="" type="radio"/>	<input checked="" type="radio"/>	<input type="radio"/>	<input type="radio"/>	50 seconds
<input type="radio"/>	<input type="radio"/>	<input checked="" type="radio"/>	<input type="radio"/>	1 minute
<input checked="" type="radio"/>	<input type="radio"/>	<input checked="" type="radio"/>	<input type="radio"/>	1 minute 30 seconds
<input type="radio"/>	<input checked="" type="radio"/>	<input checked="" type="radio"/>	<input type="radio"/>	2 minutes
<input checked="" type="radio"/>	<input checked="" type="radio"/>	<input checked="" type="radio"/>	<input type="radio"/>	3 minutes
<input type="radio"/>	<input type="radio"/>	<input type="radio"/>	<input checked="" type="radio"/>	4 minutes
<input checked="" type="radio"/>	<input type="radio"/>	<input type="radio"/>	<input checked="" type="radio"/>	5 minutes
<input type="radio"/>	<input checked="" type="radio"/>	<input type="radio"/>	<input checked="" type="radio"/>	6 minutes
<input checked="" type="radio"/>	<input checked="" type="radio"/>	<input type="radio"/>	<input checked="" type="radio"/>	7 minutes
<input type="radio"/>	<input type="radio"/>	<input checked="" type="radio"/>	<input checked="" type="radio"/>	8 minutes
<input checked="" type="radio"/>	<input type="radio"/>	<input checked="" type="radio"/>	<input checked="" type="radio"/>	9 minutes
<input type="radio"/>	<input checked="" type="radio"/>	<input checked="" type="radio"/>	<input checked="" type="radio"/>	10 minutes
<input checked="" type="radio"/>	<input checked="" type="radio"/>	<input checked="" type="radio"/>	<input checked="" type="radio"/>	other value (if the value programmed in the control panel does not correspond to any of these shown above – the value cannot be set using the buttons )



Table 4. Presentation of time using the LEDs (○ - LED OFF; ● - LED ON).

6. Press the  button to save the changes made.

7. Programming the cut off time of relay outputs

1. Using the buttons **6**, select the function 7 (see: Table 1, p. 29).
2. Press the  button.
3. Press one of the buttons **7** to select the relay output for which the cut off time will be programmed.
4. Press the  button.
5. Using the buttons **6**, specify the cut off time (see: Table 4, p. 32).
6. Press the  button to save the changes made.

8. Programming the input type



1. Using the buttons **6**, select the function 8 (see: Table 1, p. 29).
2. Press the  button.
3. Press one of the buttons **6** to select the input for which the type will be programmed.
4. Press the  button.
5. Using the buttons **6**, specify the input type.

LED number			Input type
1	2	3	
●	○	○	disabled
○	●	○	fire damper
●	●	○	auxiliary device fault
○	○	●	transmission confirmation
●	○	●	class change

Table 5. Presentation of the operating mode using the LEDs (○ - LED OFF; ● - LED ON).



6. Press the  button to save the changes made.

9. Programming the input options



1. Using the buttons **6**, select the function 9 (see: Table 1, p. 29).
2. Press the  button.
3. Press one of the buttons **6** to select the input of TRANSMISSION CONFIRMATION type, for which options will be programmed.
4. Press the  button.

5. Using the **1** and **2** buttons, specify the options. The ON LEDs indicate that the following options have been selected:
 - 1 – confirmation of fire alarm transmission;
 - 2 – confirmation of fault warning transmission.
6. Press the  button to save the changes made.

10. Programming the delay time for inputs

1. Using the buttons **6**, select the function 10 (see: Table 1, p. 29).
2. Press the  button.
3. Press one of the buttons **6** to select the input for which the delay time will be programmed.
4. Press the  button.
5. Using the buttons **6**, specify the delay time (see: Table 4, p. 32).
6. Press the  button to save the changes made.

11. Programming the sounder parameters

1. Using the buttons **6**, select the function 11 (see: Table 1, p. 29).
2. Press the  button.
3. Press the **1** or **2** button to select the sounder for which the operating mode will be programmed.
4. Press the  button.
5. Using the **1** and **2** buttons, specify the operating mode.



LED number		Sounder operating mode
1	2	
●	○	alarm II
○	●	alarm I or II
●	●	alarm I (p) or II

Table 6. Presentation of the sounder operating mode using the LEDs (○ - LED OFF; ● - LED ON).



6. Press the  button to save the changes made.

12. Enabling / disabling routing outputs



1. Using the buttons **6**, select the function 12 (see: Table 1, p. 29).
2. Press the  button.

3. Press the **1** button (enabling/disabling the fire alarm routing output) or the **2** button (enabling/disabling the fault warning routing output).
4. Press the  button.
5. Using the **1** and **2** buttons, enable or disable the routing output. The ON LED indicates (only one LED can be ON) that:
 - 1 – routing output enabled;
 - 2 – routing output disabled.
6. Press the  button to save the changes made.



13. Enabling / disabling the automatic sounder restore option



1. Using the buttons **6**, select the function 13 (see: Table 1, p. 29).
2. Press the  button.
3. Using the **1** and **2** buttons, enable or disable the option. The ON LED indicates (only one LED can be ON) that:
 - 1 – option is enabled;
 - 2 – option is disabled.
4. Press the  button to save the changes made.

14. Programming the verification time

1. Using the buttons **6**, select the function 14 (see: Table 1, p. 29).
2. Press the  button.
3. Using the buttons **6**, specify the verification time (see: Table 4, p. 32 – the 10 minutes value cannot be programmed).
4. Press the  button to save the changes made.

15. Enabling / disabling panel support

1. Using the buttons **6**, select the function 15 (see: Table 1, p. 29).
2. Press the  button.
3. Press the **1** button (enabling/disabling support of the repeater panel) or the **2** button (enabling/disabling support of the virtual panel).
4. Press the  button.

5. Using the  and  buttons, enable or disable the panel support. The ON LED indicates (only one LED can be ON) that:

1 – support is enabled;

2 – support is disabled.

6. Press the  button to save the changes made.

Note: For the CSP-104 and CSP-108 control panels, you cannot use the buttons to program remaining parameters of the panels. In order to program them, you must use the DCSP program.

Completion of programming

In order to end the programming, turn the key switch counterclockwise.

8. Repeater panels

To each fire alarm control panel you can connect a repeater panel, which may be installed within the protected premises at a considerable distance (up to 1000 m) from the control panel:

PSP-104 – panel for operation of the CSP-104 control panel;

PSP-108 – panel for operation of the CSP-108 control panel;

PSP-204 – panel for operation of the CSP-204 control panel;

PSP-208 – panel for operation of the CSP-208 control panel.

Note: A fault in the repeater panel does not affect the basic functions of the control panel.

8.1 Features

- Remote operation of the control panel at levels 1 and 2 as from the control panel front panel.
- Connection to the control panel via communication bus.
- LED indicators of the status of fire alarm control panel and external devices.
- Built-in sounder.
- LCD display (PSP-204 and PSP-208).
- Switching-mode power supply, output current 2.5 A.
- Automatic switchover to backup power supply (battery) in the event of main power supply failure.

8.2 Description of repeater panels

Repeater panels are offered in the same enclosure as fire alarm control panels (see: Fig. 1).

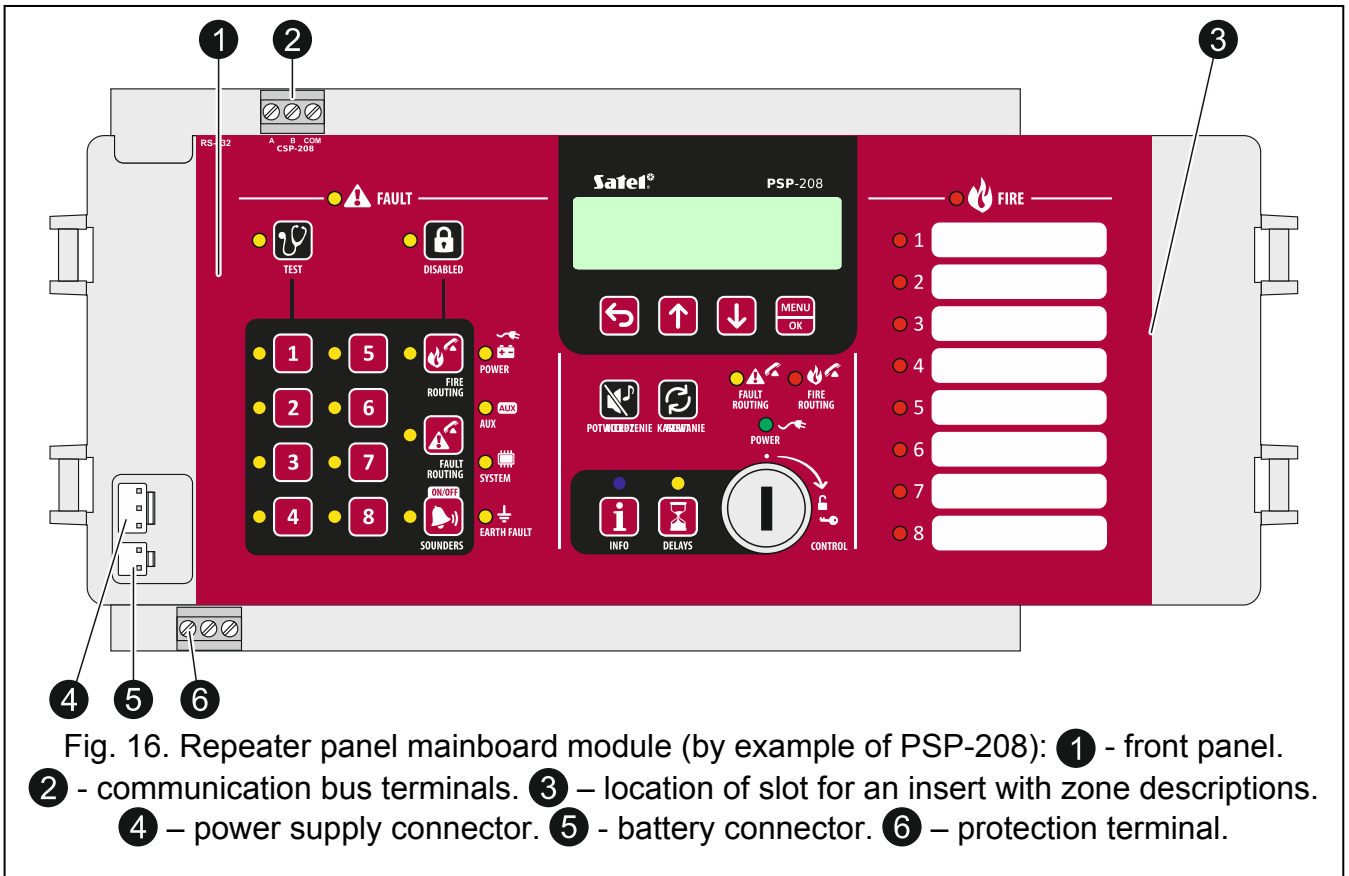

Fig. 16. Repeater panel mainboard module (by example of PSP-208): ① - front panel. ② - communication bus terminals. ③ – location of slot for an insert with zone descriptions. ④ – power supply connector. ⑤ - battery connector. ⑥ – protection terminal.

8.2.1 Front panel

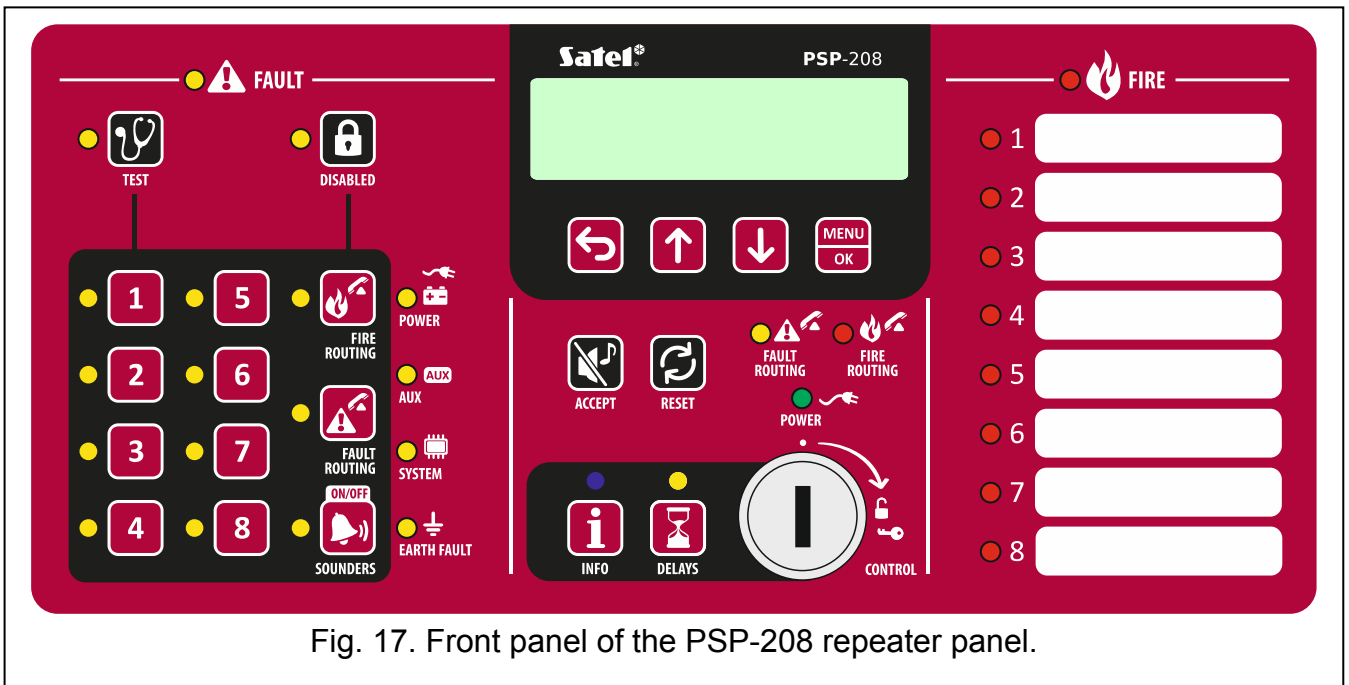

Fig. 17. Front panel of the PSP-208 repeater panel.

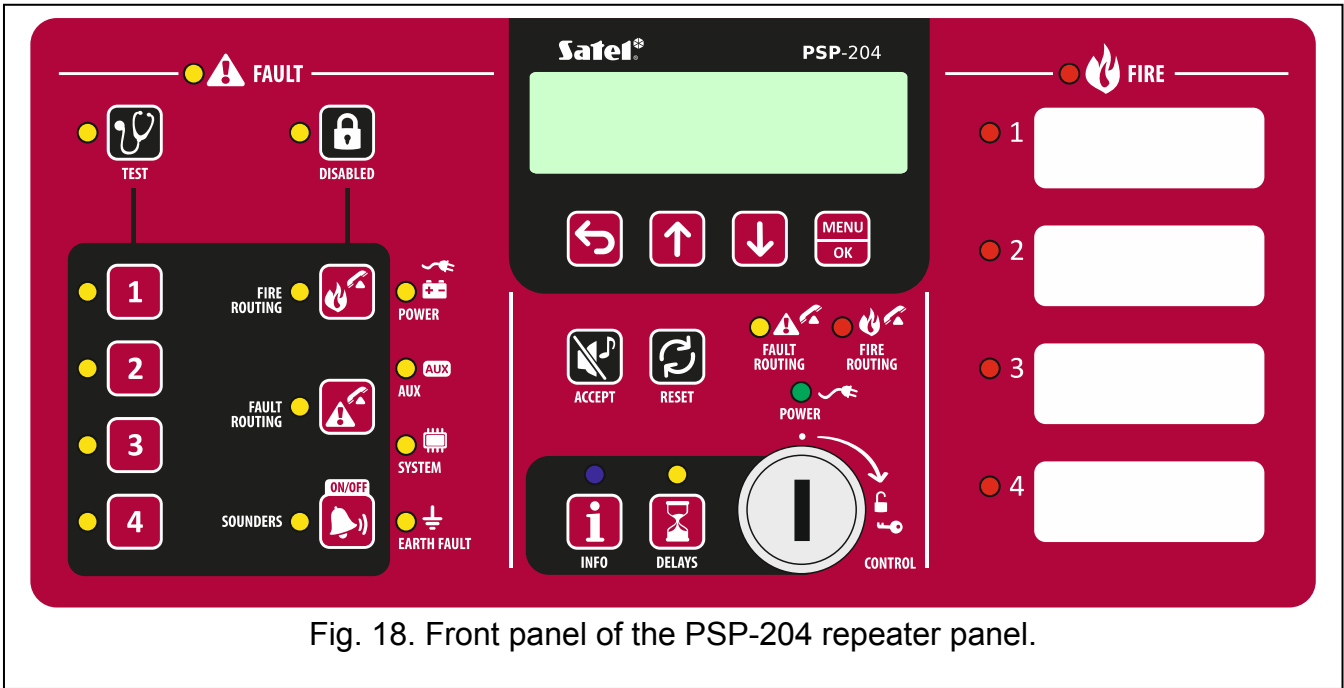

Fig. 18. Front panel of the PSP-204 repeater panel.

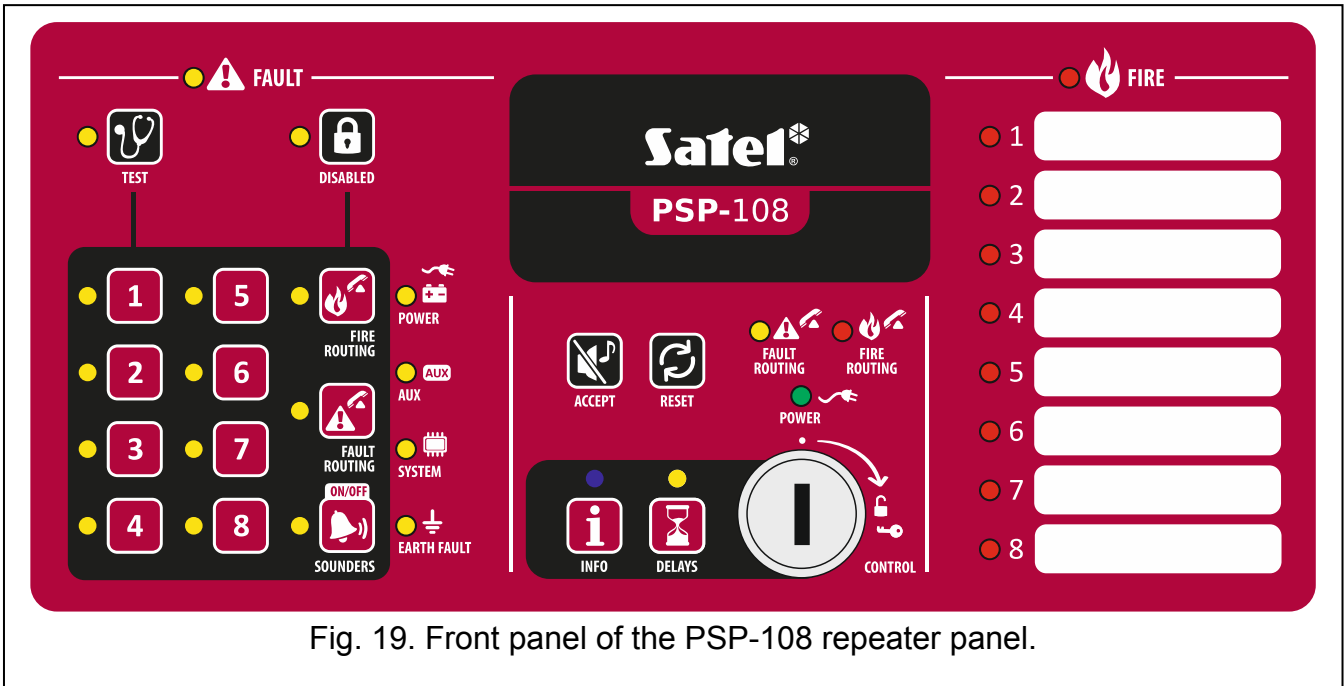

Fig. 19. Front panel of the PSP-108 repeater panel.

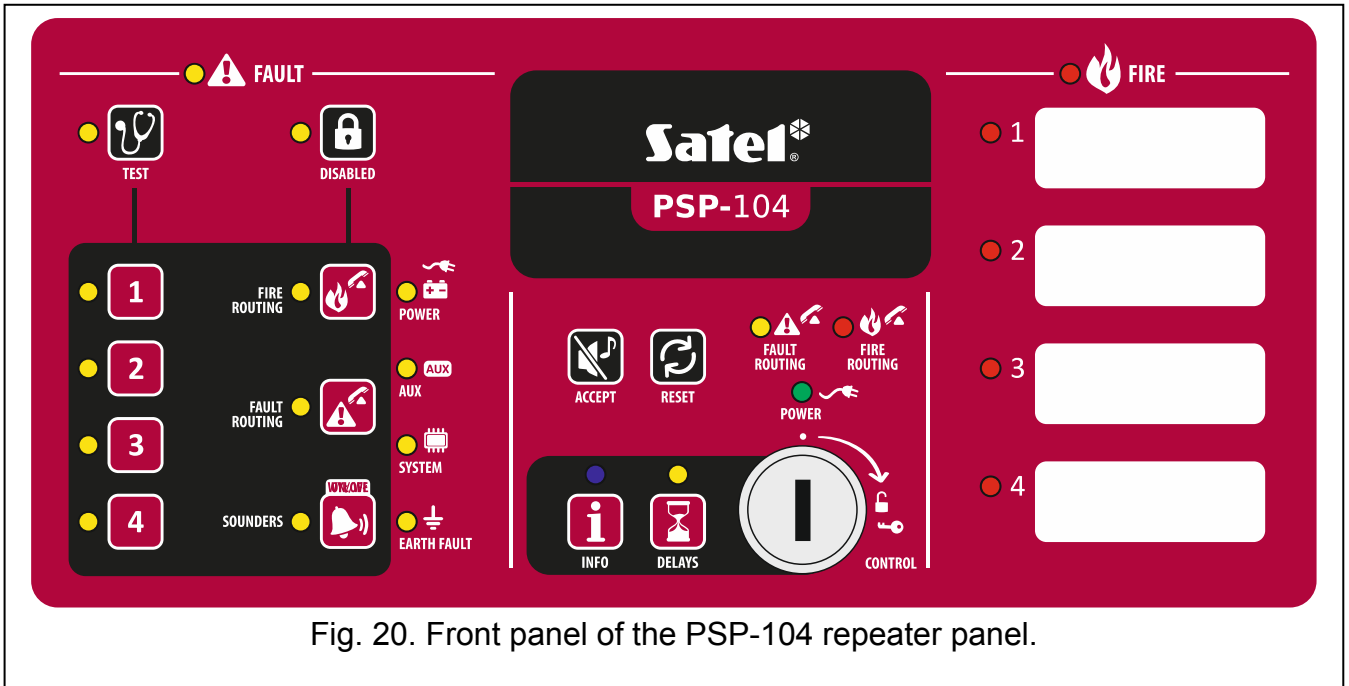

Fig. 20. Front panel of the PSP-104 repeater panel.

LED indicators

Most of the indicators function in the same way as their counterparts on the control panel's front panel (see: p. 8), the only difference being the blue LED described in the table below.

LED	Description	Color	Indications
	info	blue	slow blinking – access level 2 ON – repeater panel cannot be operated

Buttons

The buttons execute the same functions as the corresponding buttons on the control panel's front panel, when operating the control panel at level 1 and 2 (see: p. 10). The only difference is the button which replaces the button and is described in the table below.

Button	Access level	Function
	1	- checks whether operation at level 2 is available on the control panel's front panel

Key switch

The key switch allows to gain access at level 2 (see: ACCESS LEVELS, p. 18).

Display

The display is installed in CSP-204 and CSP-208 repeater panels. It allows to view the alarm and event logs and to better identify the current faults and program the control panel clock.

8.3 Installation of the repeater panel



Disconnect power before making any electrical connections.

8.3.1 Mounting the repeater panel

The repeater panel should be mounted in the same way as the control panel (p. 11).

8.3.2 Connections

1. Connect the A, B and COM terminals to the communication bus (see: COMMUNICATION BUS, p. 16).
2. Connect the main supply (see: MAIN POWER SUPPLY, p. 16).

Note: *The repeater panel must be connected to the same PE protective circuit as the control panel.*

3. Connect the backup power supply (see: BACKUP POWER SUPPLY, p. 18).

9. CSP-ETH module for communication with the virtual panel

The CSP-ETH module is an extra, optional component for fire alarm control panels. It allows the possibility of remotely viewing the control panel state by means of a computer with access to the Ethernet (TCP/IP) network. A Web browser and the Java Virtual Machine must be installed on the computer.

FreeRTOS is used in this product (www.freertos.org).

Note: *The device is only designed for use in the local area networks (LAN). It cannot be connected directly to public computer networks (MAN, WAN). For connection to a public network you must use an xDSL router or modem.*

9.1 Electronics board description

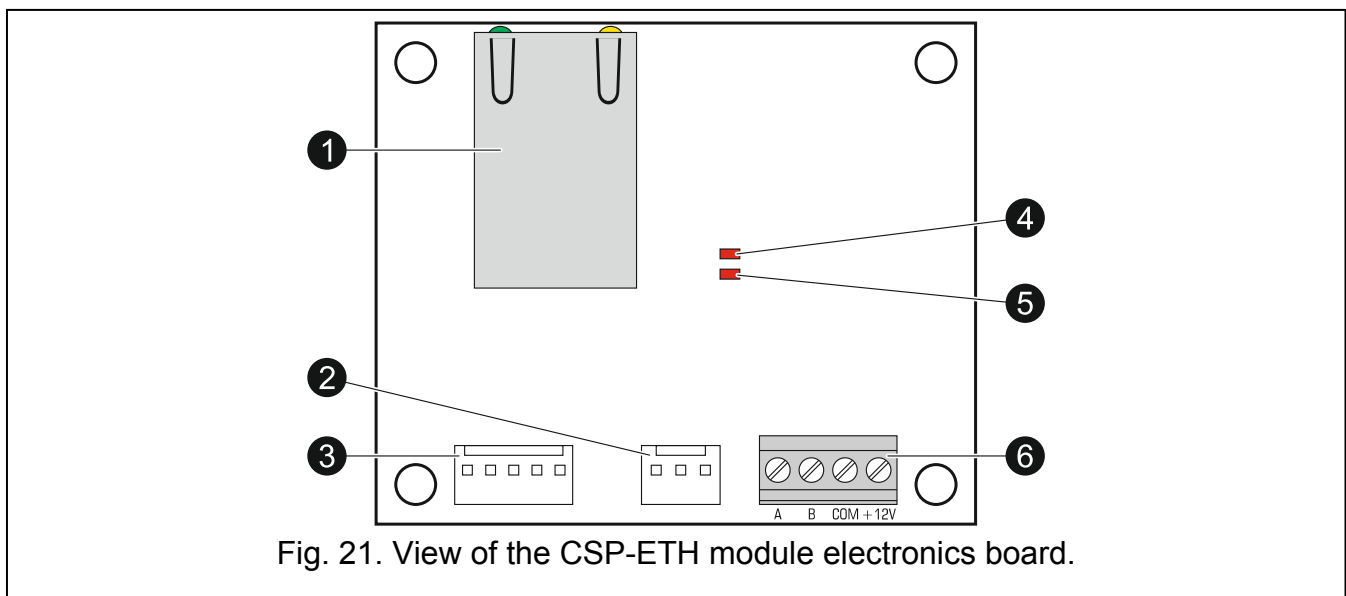

Fig. 21. View of the CSP-ETH module electronics board.

- 1 RJ-45 socket for connecting the module to Ethernet network. 100Base-TX standard compatible cable should be used. The socket has two built-in LEDs. The green one indicates connection to the network and data transmission, and the yellow one - negotiated transmission rate (ON: 100 Mb; OFF: 10 Mb).
- 2 unused connector.

- ③ unused connector.
- ④ LED indicating whether the module is supported by the control panel:
 - blinking – module is not supported;
 - ON – module is supported.
- ⑤ LED indicating whether the virtual panel is active:
 - blinking – virtual panel is not active;
 - ON – virtual panel is active.
- ⑥ terminals:
 - A, B** - communication bus terminals.
 - COM** - common ground.
 - +12V** - power input.

9.2 Installation



Disconnect power before making any electrical connections.

1. Remove the control panel mainboard module from its mountings (see: MOUNTING THE CONTROL PANEL, p. 11).
2. Attach the CSP-ETH module with screws to the underside of control panel mainboard module.

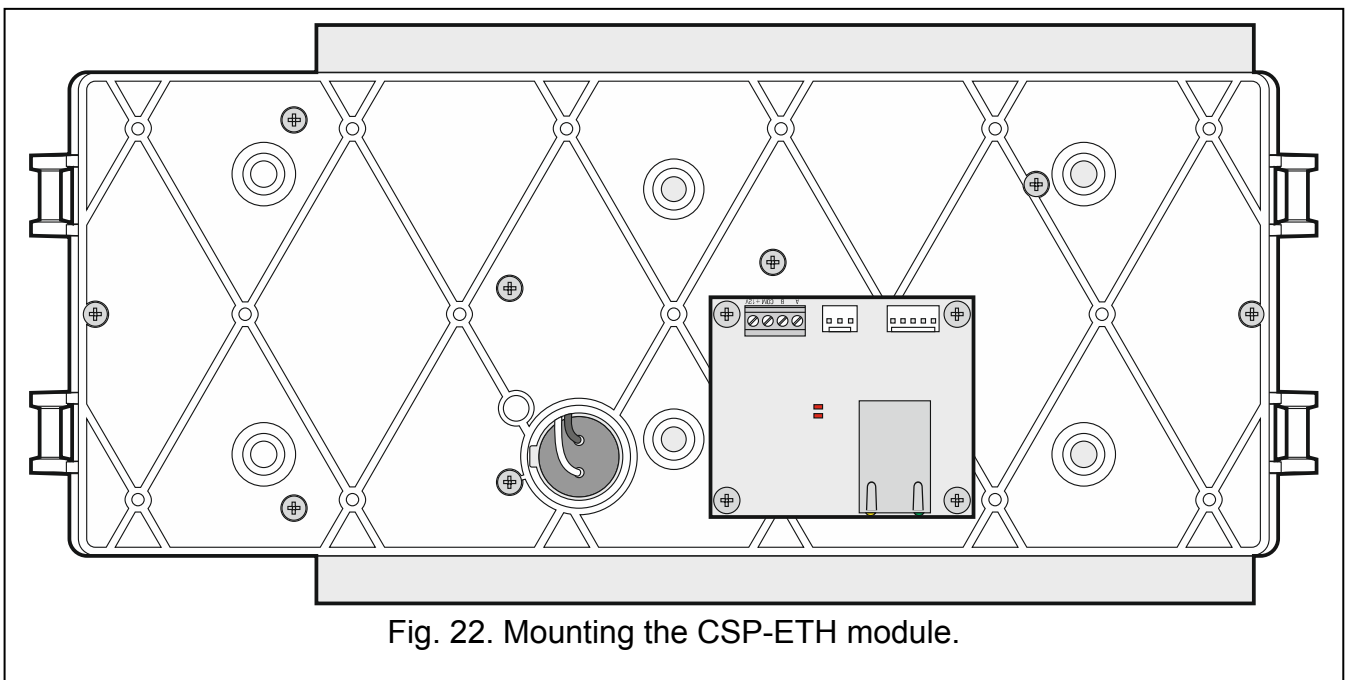

Fig. 22. Mounting the CSP-ETH module.

3. Connect the module A, B and COM terminals to the communication bus (see: COMMUNICATION BUS, p. 16).
4. Connect the module +12V and COM terminals to the control panel AUX terminals (+12V to +; COM to -).
5. Install the control panel mainboard module in its mountings inside the enclosure.
6. Connect the Ethernet network cable to the module RJ-45 socket. If the network cable is missing, the module will not start up.

Note: The module programming should be performed through the fire alarm control panel to which the module is connected.

9.3 Using the virtual panel

Note: The Web browser for communication with the CSP-ETH module uses port 80. The Java applet, which is downloaded from the module by the web browser, uses port 11010 for communication.

1. Start the web browser.
2. Enter the module IP address into the address bar and press ENTER key.
3. The login page will open in the web browser. Enter the code (by default: satel) to get access to the virtual panel.

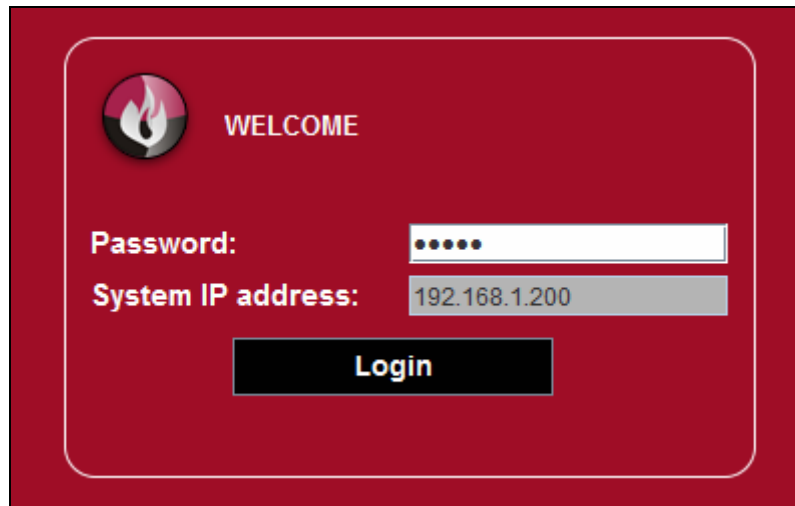



Fig. 23. Login to the virtual panel.





4. The virtual panel will be displayed.

10. Checking the fire alarm control panel for proper functioning

- I. Carry out a test of the control panel LEDs and acoustic signaling. To do this, press and hold down the  button for approx. 3 seconds at access level 2. All the LEDs should start blinking uniformly and an intermittent audible signal should be heard.
- II. Make sure that the control panel is correctly powered (the green LED, described as POWER, should be ON).
- III. Make sure that the control panel is signaling no faults, disablements or alarms (at access level 1 no LED should be ON or blinking, except for the green LED described as POWER).
- IV. In the case of CSP-204 and CSP-208 control panels, make sure that the actual time is shown on the display.
- V. Check that the control panel correctly detects any faults.



Note: Testing for faults should result in activation of the fault warning routing output, if the output is enabled.

1. Disconnect the 230 V AC mains supply.
2. After about 25 minutes:
 - the green LED described as POWER should start blinking;
 - the yellow LED described as FAULT should turn ON;
 - the yellow LED described as POWER should start blinking;

- an acoustic signal should be heard.
 - 3. Press the  button to silence the control panel acoustic signaling.
 - 4. Connect the 230 V AC mains supply. All indicators should return to the state as in point III above.
 - 5. Disconnect the battery.
 - 6. After about 2 minutes:
 - the yellow LED described as FAULT should turn ON;
 - the yellow LED described as POWER should start blinking;
 - an acoustic signal should be heard.
 - 7. Press the  button to silence the control panel acoustic signaling.
 - 8. Connect the battery. All indicators should return to the state as in point III above.
 - 9. Break the zone 1 circuit (e.g. remove a detector selected at random from its socket):
 - the yellow LED described as FAULT should turn ON;
 - the yellow LED next to the button with digit corresponding to the zone number should start blinking;
 - an acoustic signal should be heard.
 - 10. Press the  button to silence the control panel acoustic signaling.
 - 11. Restore the zone 1 circuit to its normal state (put the detector back to its socket). All indicators should return to the state as in point III above.
 - 12. Short the zone 1 circuit:
 - the yellow LED described as FAULT should turn ON;
 - the yellow LED next to the button with digit corresponding to the zone number should start blinking;
 - an acoustic signal should be heard.
 - 13. Press the  button to silence the control panel acoustic signaling.
 - 14. Restore the zone 1 circuit to its normal state. All indicators should return to the state as in point III above.
 - 15. Repeat the operations described in 9-14 for the other zones.
 - 16. Carry out the same tests for breaking and short the circuit for sounders, routing outputs and inputs. The trouble should be signaled by:
 - turning ON of the yellow LED described as FAULT;
 - blinking of the yellow LED described as SOUNDERS, for the sounders;
 - blinking of the yellow LED described as FIRE ROUTING, for the fire alarm routing outputs;
 - blinking of the yellow LED described as FAULT ROUTING, for the fault warning routing outputs;
 - blinking of the yellow LED described as AUX, for the inputs;
 - acoustic signal.
- VI. Check that the control panel correctly detects alarms.
1. Trigger an alarm in the zone 1. To this effect, depending on the type of devices connected to the zone, activate a randomly selected detector (in the case of type A dependent zone, the detector must be activated twice within a time interval less than 60 seconds) or a MCP (using the key).

2. After a few seconds:
 - the red LED designated with a digit corresponding to the zone number should start blinking;
 - the red LED described as FIRE should start blinking (in the case of a type B dependent zone, the LED should remain OFF);
 - an acoustic signal should be heard.

Note: *Additionally, the alarm triggering should result in activation of the sounders, fire alarm routing output and relay outputs, if this is provided for by the control panel configuration.*

3. Press the  button to silence the control panel acoustic signaling.
4. Turn the key switch to the position designated by the  symbol to get access at level 2.
5. Press the  button to clear the alarm (if an MCP is activated, you must reset it first).
6. Repeat the operations described in steps 1-5 for the other zones.

11. Maintenance

The fire alarm system requires a regular maintenance. It is recommended that the periodical tests be carried out at least once a year. For spaces with harsh environment (e.g. due to dustiness, aggressive conditions which may cause corrosion, etc.), the frequency of periodical tests should be increased.

Within the maintenance work, you are to perform the following operations:

1. Carry out a test for control panel LEDs and acoustic signaling.
2. Read the events logged into the control panel memory.
3. Check the condition of control panel battery.
4. Check that, after loss of the 230 V AC mains supply, the control panel will automatically switch over to the backup power supply.
5. If a repeater panel is connected to the control panel, repeat for the repeater panel the operations described in points 1, 3 and 4.
6. Perform a visual control of all detectors and MCPs.
7. Carry out a test for detectors and MCPs.
8. Carry out a test for sounders.
9. Carry out a test for routing outputs.

11.1 Fuse replacement in the battery charging system

The battery charging system in control panels and repeater panels is protected by a SSTC 3.5 slow-blow fuse, manufactured by Bel Fuse, rated at 3.5 A. Location of the fuse is shown in Fig. 24. If the fuse blows, replace it with a new one. The fuses are available in product portfolio offered by SATEL.

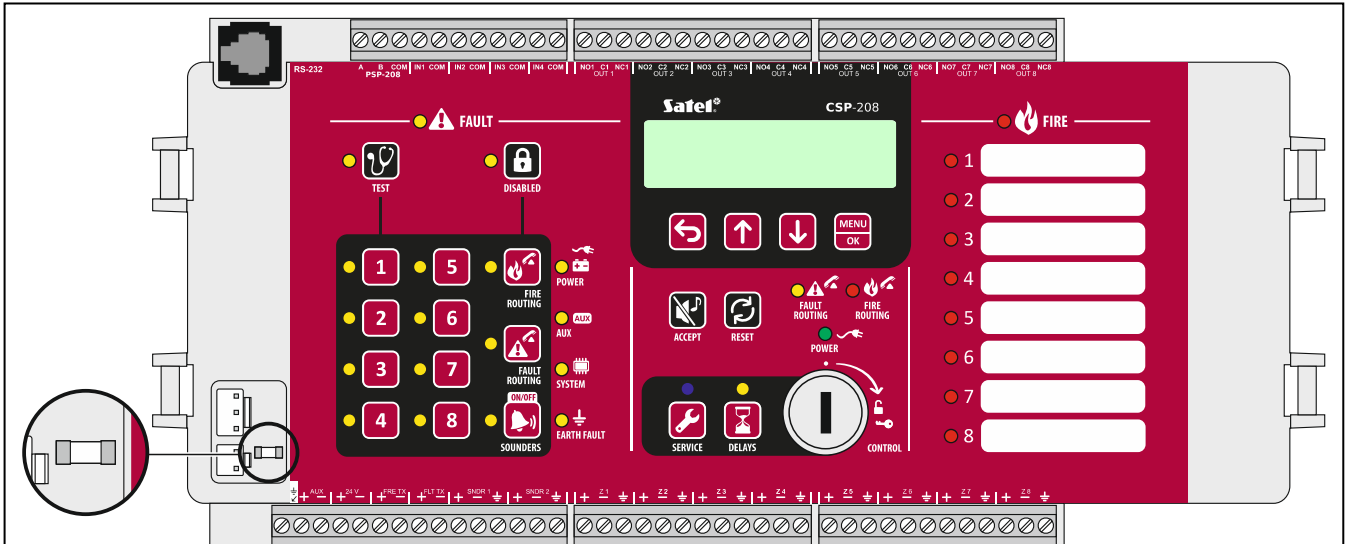

Fig. 24. Location of the fuse by example of CSP-208 mainboard module (the fuse location is the same in all control panels and repeater panels).

12. Specifications

12.1 Control panels

Main power supply	230 V AC +10%, -15% 50 Hz
Maximum mains current consumption.....	0.5 A
Power supply overcurrent protection.....	slow-blow fuse 3.15 A
Current parameters of integrated power supply (acc. to EN54-4):	
I _{max a}	2.5 A
I _{max b}	3.6 A
Backup power supply:	
internal lead-acid battery	12 V / 17 Ah e.g. HV17-12W KOBE
external lead-acid battery	12 V / ≤24 Ah e.g. HP24-12W KOBE
Backup battery life	72 h
Battery charging current, max	1.4 A
Battery charging system overcurrent protection.....	slow-blow fuse 3.5 A
Maximum battery internal resistance (with wires and terminals in circuit).....	1 Ω
Current consumption from battery – quiescent condition:	
CSP-208	140 mA
CSP-204	100 mA
CSP-108	140 mA
CSP-104	100 mA
Current consumption from battery – fire alarm condition:	
CSP-208	215 mA
CSP-204	170 mA
CSP-108	215 mA
CSP-104	170 mA
Current consumption from integrated power supply – quiescent condition:	
CSP-208	115 mA
CSP-204	80 mA
CSP-108	105 mA
CSP-104	75 mA
Current consumption from integrated power supply – fire alarm condition:	
CSP-208	170 mA
CSP-204	140 mA
CSP-108	155 mA
CSP-104	130 mA
Zone number:	
CSP-208 / CSP-108	8
CSP-204 / CSP-104	4
Maximum zone circuit resistance	100 Ω (2 x 50 Ω)
Maximum number of detectors in zone circuit.....	32
Maximum number of manual call points (MCPs) in zone circuit.....	10
End-of-line resistor in zone circuit.....	5.6 k Ω +/- 5%

Permissible quiescent current in zone circuit	10 mA
Maximum current in zone circuit during fire alarm	40 mA
Current limiting level in zone circuit	54 mA
Maximum resistance of sounder, alarm and fault circuits	75 Ω (2 x 32.5 Ω)
Number of sounder circuit	2
Working voltage in sounder circuit	24 V DC +/-15%
Permissible current in sounder circuit	180 mA
End-of-line resistor in sounder circuit	10 k Ω +/-5%
Number of fire alarm routing circuits	1
Working voltage in fire alarm routing circuit	24 V DC +/-15%
Permissible current in fire alarm routing circuit	180 mA
End-of-line resistor in fire alarm routing circuit	10 k Ω +/-5%
Number of fault warning routing circuits	1
Working voltage fault warning routing circuit	24 V DC +/-15%
Permissible current in fault warning routing circuit	180 mA
End-of-line resistor in fault warning routing circuit	10 k Ω +/-5%
Number of programmable relay outputs:	
CSP-208 / CSP-108	8
CSP-204 / CSP-104	4
Electrical parameters of relay outputs	1A / 30 V DC (NO or NC)
Number of programmable inputs	4
End-of-line resistor in input circuit	10 k Ω +/- 5%
Alarm resistor in input circuit	1 k Ω +/- 5%
AUX power supply output (only for connecting CSP-ETH module):	
normal condition	18 V DC +5%, -15%
AC mains failure	12 V DC +15%, -20%
+24V power supply output	24 V DC +/-15% / 200 mA max
Output for communication with repeater panel and CSP-ETH module	serial transmission
End-of-line resistor on terminals for communication with repeater panel	100 Ω
Output for communication with PC computer (service)	RJ11 / serial transmission
Clock battery	3 V (CR2032)
External alarm transmission delay	programmable from 0 to 10 min, every 1 s
Alarm counter capacity	9999
Event log capacity	8999
Enclosure protection rating	IP30
Maximum humidity	93 \pm 3%
Operating temperature range	-5...+40 $^{\circ}$ C
Transportation temperature range	-25...+55 $^{\circ}$ C
Dimensions	324 x 382 x 108 mm
Weight without battery	< 3 kg

12.2 Repeater panels

Main power supply	230 V AC +10%, -15% 50 Hz
Maximum mains current consumption	0.5 A

Power supply overcurrent protection.....	slow-blow fuse 3.15 A
Current parameters of integrated power supply (acc. to EN54-4):	
I _{max a}	2.5 A
I _{max b}	3.6 A
Backup power supply:	
internal lead-acid battery	12 V / 17 Ah e.g. HV17-12W KOBE
Backup battery life	72 h
Battery charging current, max	1 A
Maximum battery internal resistance (with wires and terminals in circuit).....	1 Ω
Current consumption from battery – quiescent condition	60 mA
Current consumption from battery – fire alarm condition.....	60 mA
Current consumption from integrated power supply – quiescent condition	55 mA
Current consumption from integrated power supply – fire alarm condition	55 mA
Enclosure protection rating	IP30
Maximum humidity	93±3%
Operating temperature range.....	-5...+40 °C
Transportation temperature range	-25...+55 °C
Dimensions	324 x 382 x 108 mm
Weight without battery.....	< 3 kg

12.3 CSP-ETH module

Maximum current consumption	45 mA
Maximum humidity	93±3%
Operating temperature range.....	-5...+40 °C
Transportation temperature range	-25...+55 °C
Electronics board dimensions	60 x 50 mm
Weight.....	24 g